

## STANDARDS

DESIGNED IN ACCORDANCE WITH, AND FABRICATION TO MEET THE FOLLOWING STANDARDS:

- AS1428.4.1:2009, TACTILE GROUND SURFACE INDICATORS FOR THE ORIENTATION OF PEOPLE WITH VISION IMPAIRMENT.
- AS1627.4 METAL FINISHING -PREPARATION AND PRE-TREATMENT OF SURFACES - ABRASIVE BLAST CLEANING OF STEEL.
- AS2312:2002/AMDT 1:2004, GUIDE TO PROTECTION OF IRON AND STEEL AGAINST EXTERIOR ATMOSPHERIC CORROSION, 1994.
- GUIDE TO ENGINEERING PRACTICE, 'PEDESTRIANS', PART 13, AUSTRROADS.
- AUSTRALIAN ROAD RULES , 1999, WWW.NRTC.GOV.AU
- AS4506 -2005, METAL FINISHING-THERMOSET POWDER COATINGS.
- AS4680:2006, HOT DIP GALVANISING.

## NOTES

- WELDING TO BE ACCORDANCE TO AS1554.1 CAT GP WELDING, ALL SHARP EDGES & BURRS REMOVED.
- PART SHOULD BE SUPPLIED CLEAN AND FREE FROM MARKS, BURRS, SCUFFS, DISTORTION AND WARPAGE.
- ENSURE ANTI-SEIZE IS ON ALL NUTS AND BOLTS PRIOR TO ASSEMBLY.
- DRAWING TO AS1100 DRAWING STANDARDS.
- 316 S.S AND 316 S.S FASTENERS TO BE USED THROUGHOUT FOR COASTAL INSTALLATIONS OR ANY ENVIRONMENT WITH HIGH CORROSION.
- ALL TOLERANCES  $\pm 0.5\text{mm}$  UNLESS OTHERWISE SPECIFIED.

## MATERIAL

- MATERIAL: 316 STAINLESS STEEL
- COLOUR: NATURAL
- FINISH: DEBURRED

STRUCTURAL DESIGN REVIEWED AND  
CERTIFIED FOR ISSUE

NAME: B.C. PLANT RPEQ: 8807  
SIGNATURE: ON ORIGINAL DATE: 10/ 05/ 18

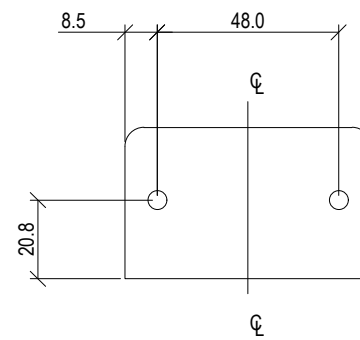
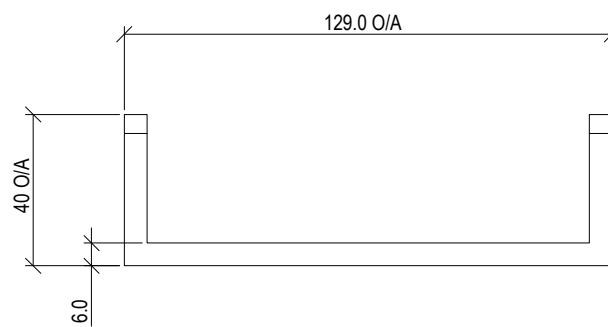
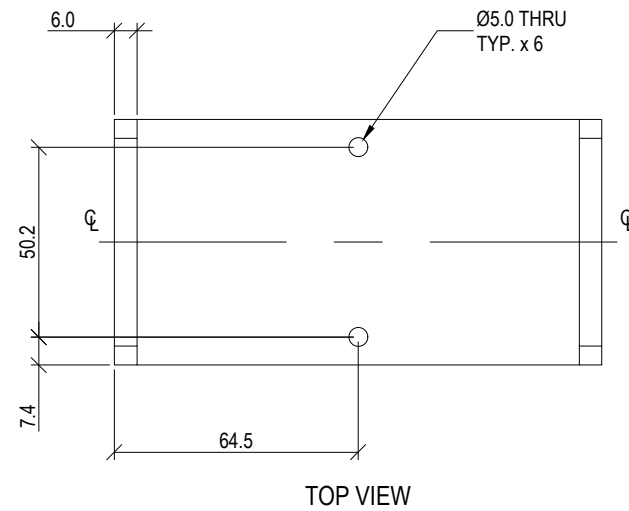
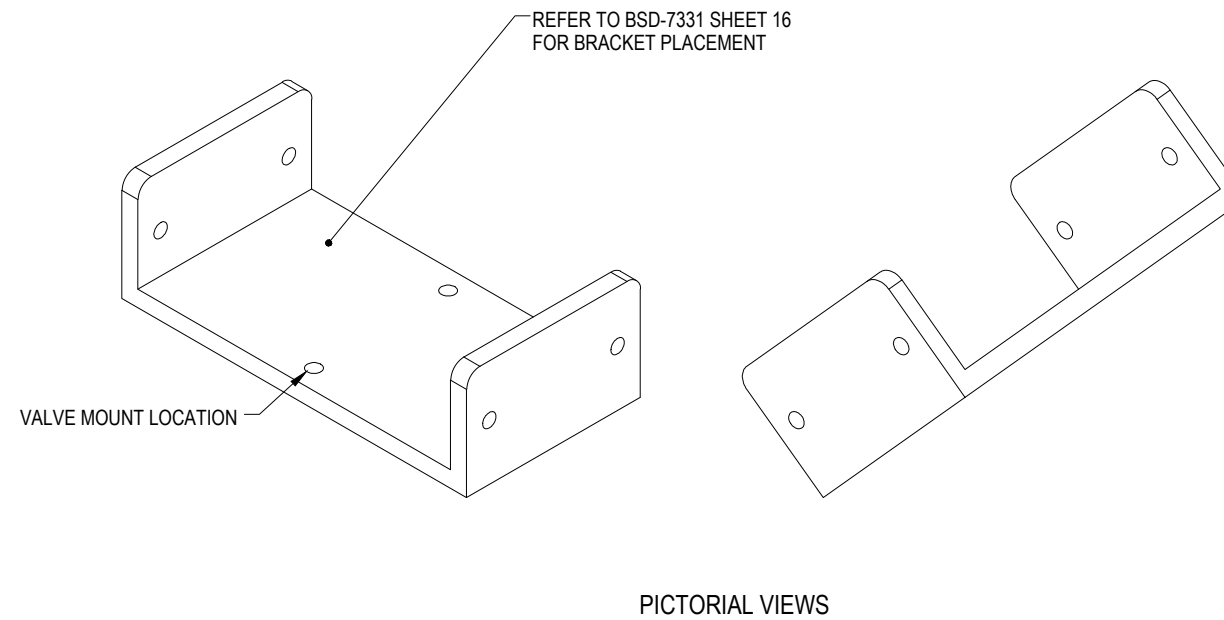

|       |                                    |            |            |  |  |      |         |                  |                |          |         |   |  |  |       |     |
|-------|------------------------------------|------------|------------|--|--|------|---------|------------------|----------------|----------|---------|---|--|--|-------|-----|
|       |                                    |            |            | DRAWING AUTHORISED FOR PUBLICATION<br>INGA CONDRIĆ<br>PRINCIPAL ENGINEER<br>STRATEGIC ASSET MANAGEMENT PLANNING<br>DESIGN APPROVED<br>VICKI MARTIN<br>PRINCIPAL PLANNING OFFICER<br>URBAN DESIGN |  |      |         | DESIGN           | FORMZOO DESIGN | DATE     | MAY '18 |  | BRISBANE CITY COUNCIL STANDARD DRAWING |  | SCALE | 1:2 |
|       |                                    |            |            | DRAWN  | SC   | DATE | MAY '18 | DWG No.          | BSD-7331       |          |         |   |  |  |       |     |
|       |                                    |            |            | CHECKED  | Urban Design   | DATE | MAY '18 | ORIGINAL SIZE    | A3             | REVISION | A       |   |  |  |       |     |
|       |                                    |            |            | DRAWING FILENAME   | BSD-7331 (A) Drinking fountain - Dog bowl valve mount - Sheet 27 of 27 |      |         | ASSOCIATED PLANS |                |          |         |   |  |  |       |     |
| A     | Original Issue - Dog Bowl Addition | MAY '18    | JUN '18    | NOV '18  | DRINKING FOUNTAIN<br>DOG BOWL VALVEMOUNT<br>SHEET 27 OF 27             |      |         |                  |                |          |         |   |  |  |       |     |
| ISSUE | AMENDMENT                          | DRAWN DATE | CHK'D DATE | APPR'D DATE  |  |      |         |                  |                |          |         |   |  |  |       |     |