

FOR DUAL 200mm LANTERNS

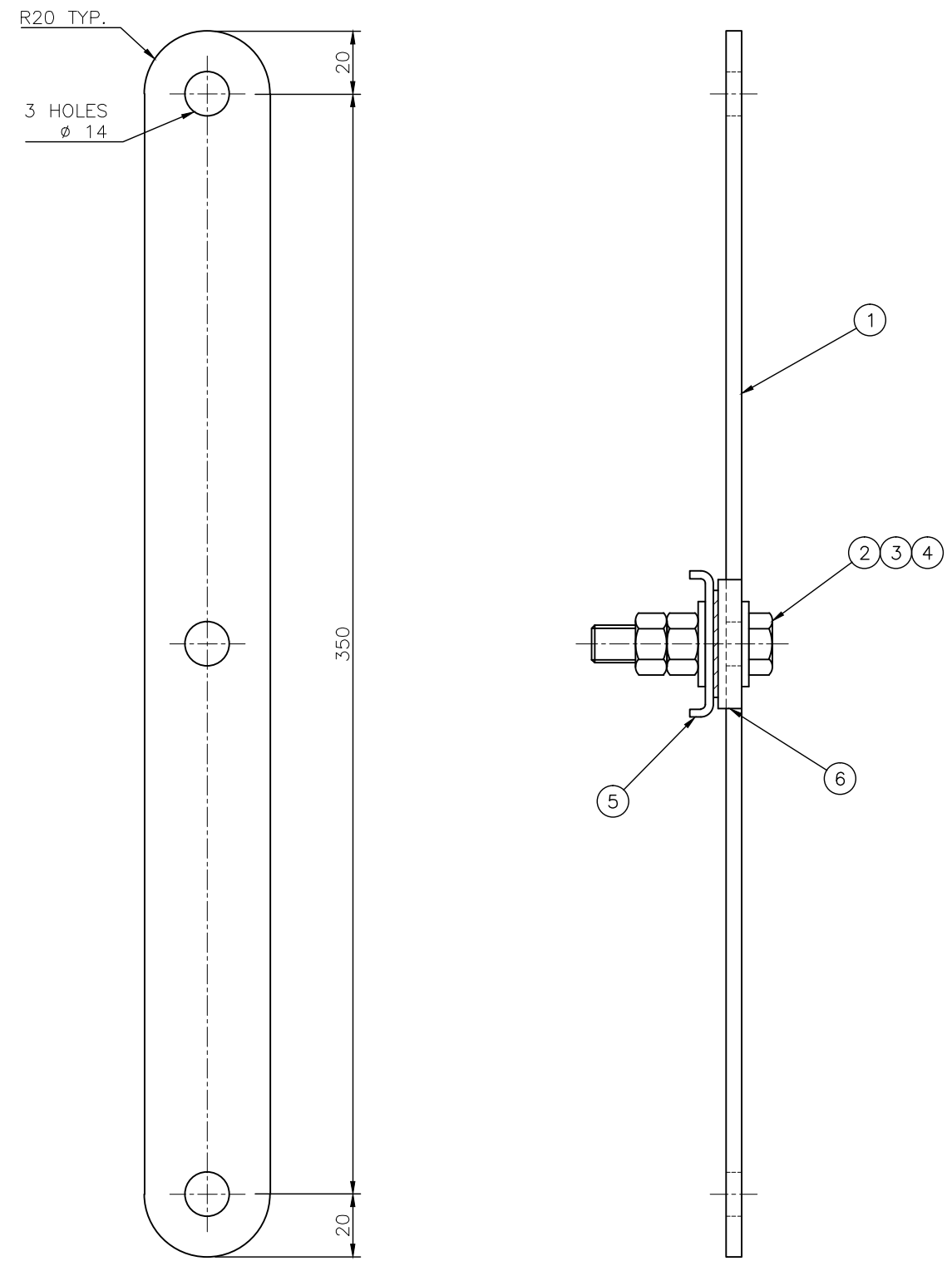

FOR DUAL 300mm LANTERNS

NOTES:

1. DEBURR AND REMOVE SHARP CORNERS AND EDGES.
2. GENERAL TOLERANCE ±1.0 AND FOR HOLE CENTRES & HOLES ±0.5
3. ALL ITEMS SHALL BE SUPPLIED AND FULLY ASSEMBLED (AS SHOWN) BY THE MANUFACTURER.
4. THE SPECIAL LOCK WASHER (ITEM 6) TO BE FITTED TO THE STRAP WITH THE STANDARD LOCK WASHER (ITEM 5), DIMPLE TO DIMPLE.
5. LOCK WASHERS TO BE MANUFACTURED TO BSD-4106.
6. ALL DIMENSIONS IN MILLIMETRES (U.N.O.).

ITEM	DESCRIPTION	MATERIAL	FINISH	QTY
6	SPECIAL LOCK WASHER (REFER BSD-4106)	STAINLESS STEEL	BLACK	1
5	STANDARD LOCK WASHER (REFER BSD-4106)	STAINLESS STEEL	NATURAL	1
4	HEX NUT M12 TO AS1112	STAINLESS STEEL	NATURAL	2
3	HEX HEAD BOLT M12x50 TO AS1111	STAINLESS STEEL	NATURAL	1
2	FLAT WASHER M12 LARGE SERIES TO AS1237	STAINLESS STEEL	NATURAL	2
1	STEEL FLAT BAR 40x5 TO AS3679	MILD STEEL	HD GALV TO AS/NZS4680	1

ISSUE	AMENDMENT	DRAWN DATE	CHK'D DATE	APPR'D DATE
A	Drawing Converted from UMS Series April 2014	APR '14	APR '14	APR '14

DRAWING AUTHORISED FOR PUBLICATION			
P COTTON SIGNATURE ON ORIGINAL			
MANAGER CITY ASSETS - R.P.E.Q. 2 5 4 6			
DESIGN APPROVED			
I. CONDRIE SIGNATURE ON ORIGINAL DATED 12/10			
PRINCIPAL ENGINEER ROAD NETWORK INFRASTRUCTURE - R.P.E.Q. 8 5 9 1			
DESIGN	Std Dwgs WG	DATE	April '09
DRAWN	CPD - P&D	DATE	April '09
CHECKED	I. Condric	DATE	Dec'10
DRAWING FILENAME	BSD-4104.dwg		
ASSOCIATED PLANS	SUPERSEDES UMS-600-043		

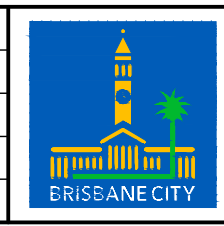

BRISBANE CITY COUNCIL STANDARD DRAWING

TEE-BAR STRAP FOR DUAL LANTERNS

SCALE: NOT TO SCALE

DWG No. **BSD-4104**

ORIGINAL SIZE: A3 REVISION: A