

SECTION A-A

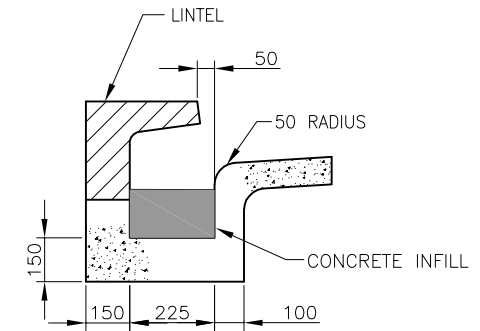

SECTION C-C
(THROUGH LINTEL)

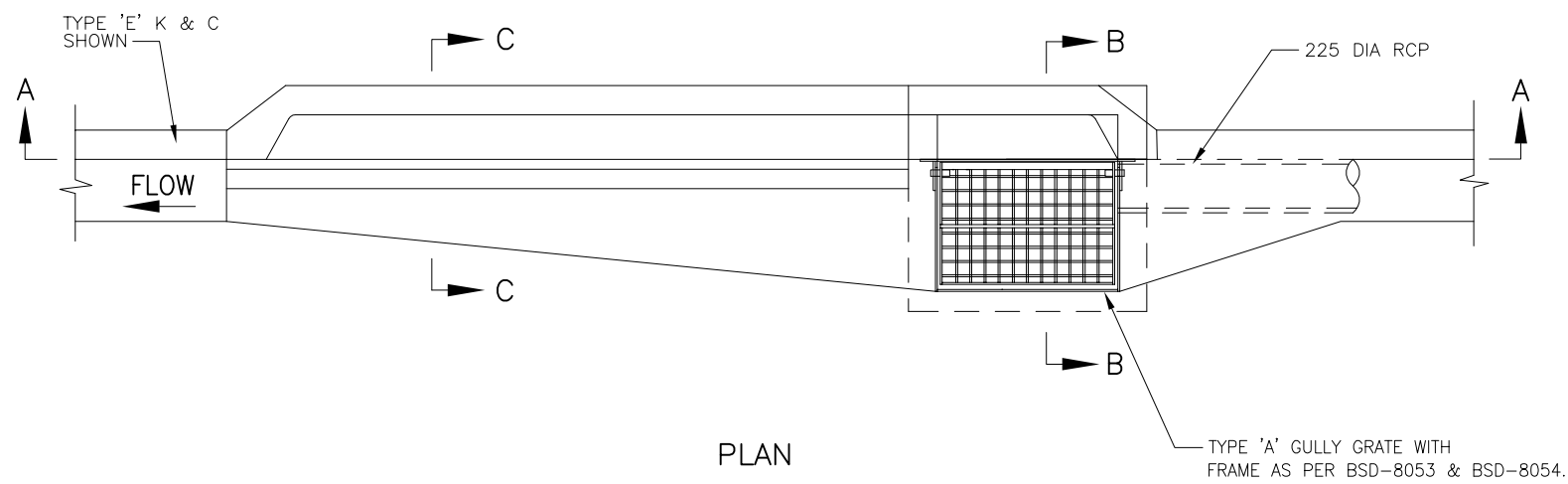

PLAN

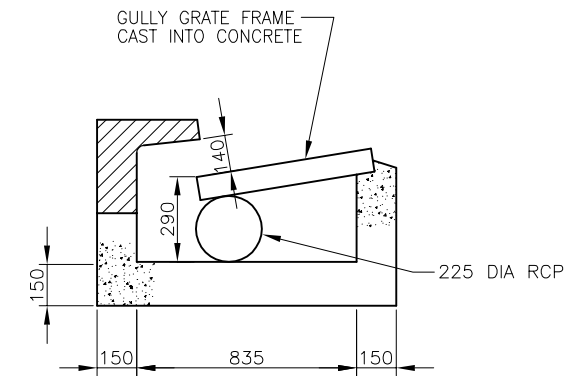

SECTION B-B

SURCHARGE GULLY

NOTES:

1. FOR COUNCIL USE ONLY. SURCHARGE GULLY ONLY TO BE USED WITH APPROVAL OF MANAGER WATERWAYS OR DELEGATED AUTHORITY. USE IS GENERALLY LIMITED TO RETROFITTING OR INFRASTRUCTURE UPGRADING.
2. FOR STANDARD GULLY COMPONENT/DIMENSION DETAIL REFER BSD-8052.
3. DIMENSIONS IN MILLIMETRES (UNO).

ISSUE	AMENDMENT	DRAWN DATE	CHK'D DATE	APPR'D DATE
A	ORIGINAL ISSUE	Mmm 'YY	Mmm 'YY	Mmm 'YY

DRAWING AUTHORISED FOR PUBLICATION
 B.BALL SIGNATURE ON ORIGINAL
 DATED 31/10/01
 MANAGER ASSET SUPPORT - R.P.E.Q: 3852

DESIGN APPROVED
 B.HANSEN SIGNATURE ON ORIGINAL
 DATED 31/10/01
 CLIENT POSITION
 COUNCIL WORK AREA OR BRANCH

DESIGN	STD DWG GROUP	DATE	APR '01
DRAWN	CITY DESIGN	DATE	APR '01
CHECKED	M.STEEER	DATE	MAY '01
DRAWING FILENAME	BSD-8059.dwg		
ASSOCIATED PLANS	SUPERSEDES UMS-338		

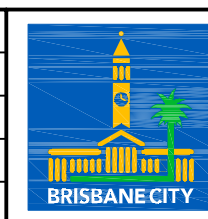

BRISBANE CITY COUNCIL STANDARD DRAWING	
SCALE NOT TO SCALE	
DWG No. BSD-8059	
ORIGINAL SIZE A3	REVISION A