

ITEM 1

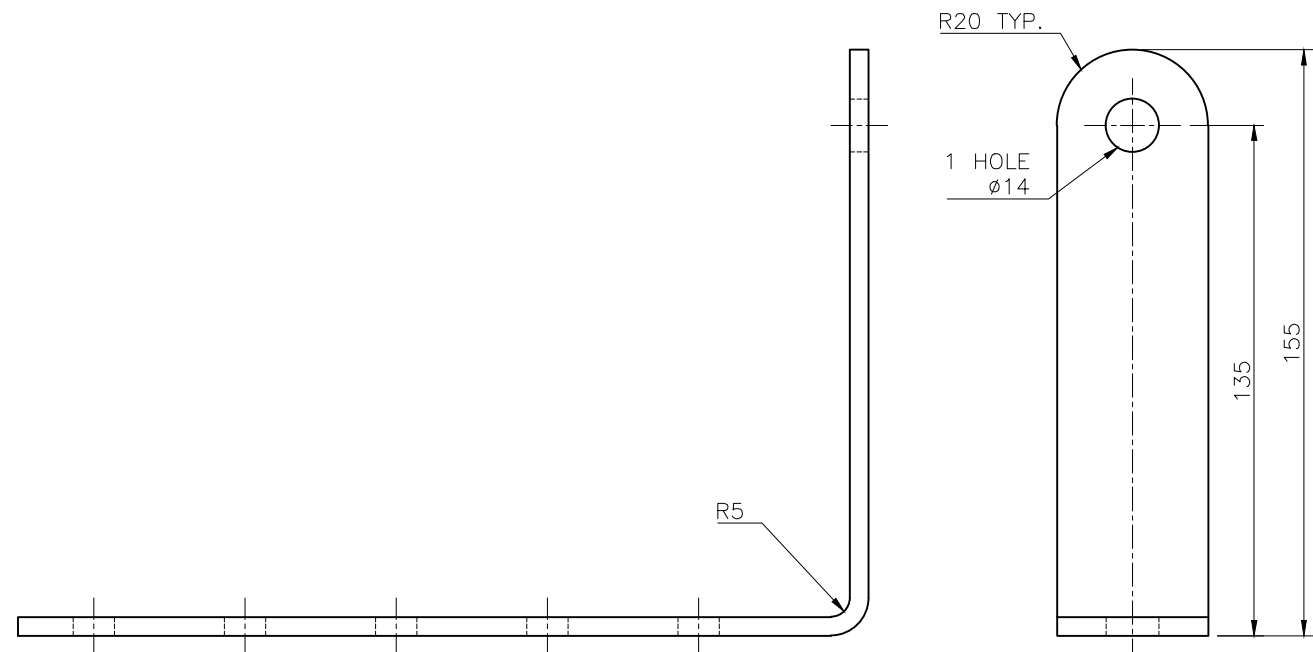

ITEM 2

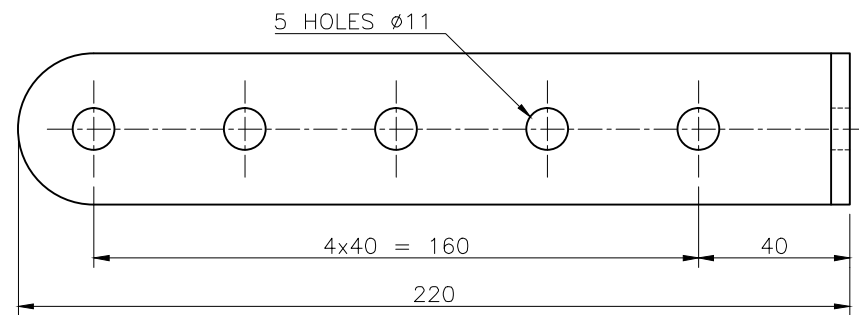
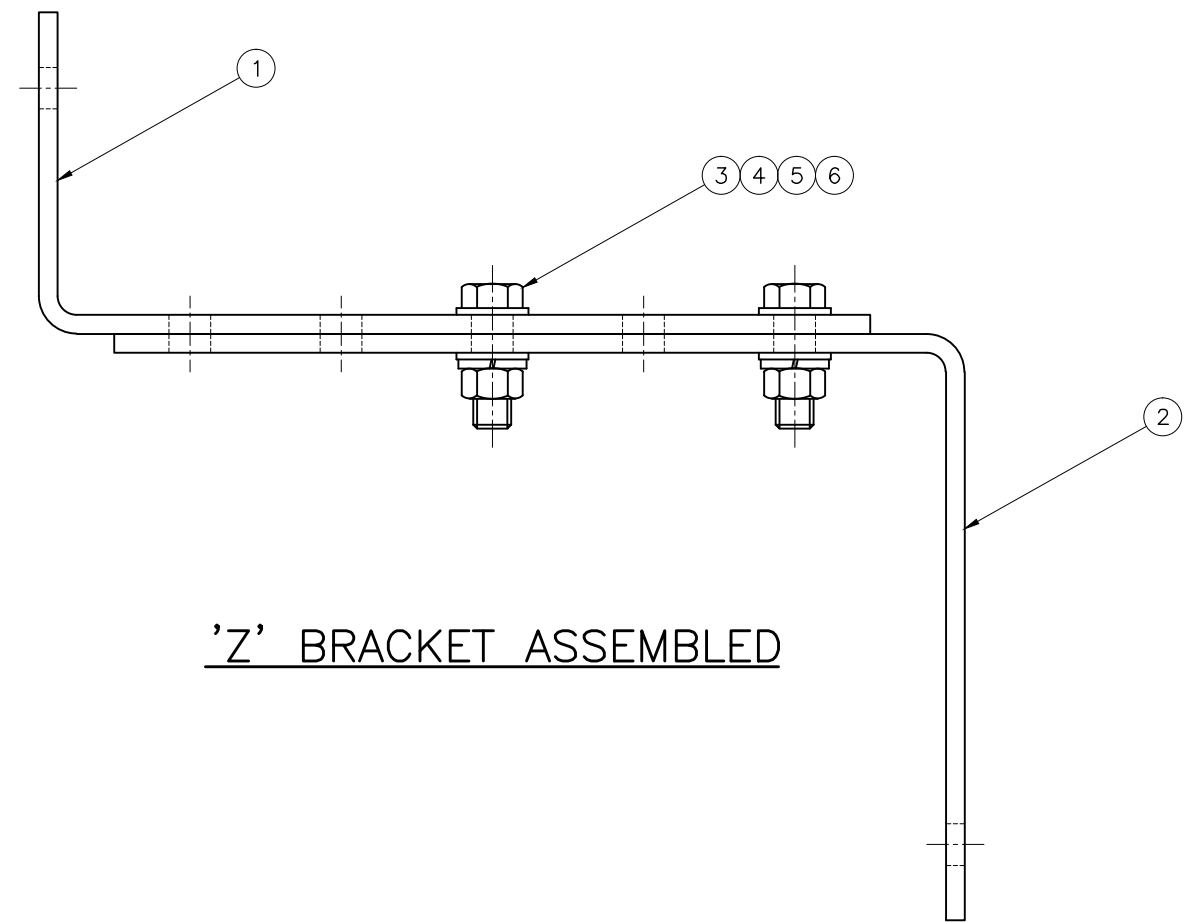
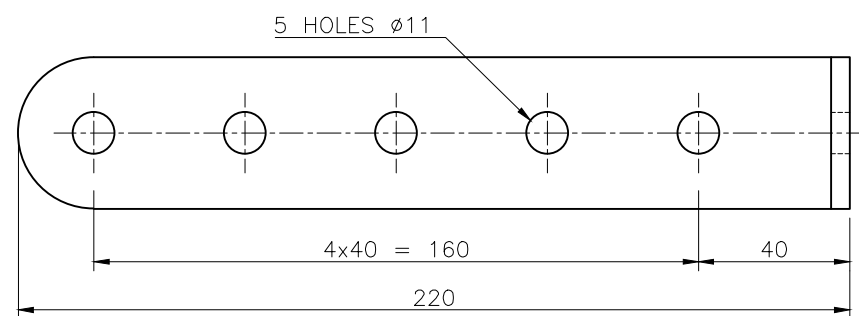

'Z' BRACKET ASSEMBLED

NOTES:

1. DEBURR AND REMOVE SHARP CORNERS AND EDGES.
2. GENERAL TOLERANCE ± 1.0 AND FOR HOLE CENTRES & HOLES ± 0.5
3. ALL ITEMS SHALL BE SUPPLIED & FITTED (AS SHOWN ABOVE) BY THE MANUFACTURER.
4. ITEMS 1 AND 2 TOLERANCES IN ACCORDANCE WITH AS3679.
5. ALL DIMENSIONS IN MILLIMETRES (U.N.O.).

ITEM	DESCRIPTION	MATERIAL	FINISH	QTY
6	FLAT WASHER M10 TO AS1237	STAINLESS STEEL	NATURAL	4
5	SPRING WASHER M10 TO AS1968	STAINLESS STEEL	NATURAL	2
4	HEX NUT M10 TO AS1112	STAINLESS STEEL	NATURAL	2
3	HEX HEAD SCREW M10x30 TO AS1111	STAINLESS STEEL	NATURAL	2
2	BRACKET ITEM 1 40x5 FLAT TO AS3679	MILD STEEL	HD GALV TO AS/NZS4680	1
1	BRACKET ITEM 2 40x5 FLAT TO AS3679	MILD STEEL	HD GALV TO AS/NZS4680	1

ISSUE	AMENDMENT	DRAWN DATE	CHK'D DATE	APPR'D DATE
A	ORIGINAL ISSUE	Oct '13	Oct '13	Oct '13

DRAWING AUTHORISED FOR PUBLICATION			
P. COTTON SIGNATURE ON ORIGINAL			
MANAGER CITY ASSETS - R.P.E.Q: 2 5 4 6			
DESIGN APPROVED			
I. CONDRIK SIGNATURE ON ORIGINAL DATED 12/10			
PRINCIPAL ENGINEER ROAD NETWORK INFRASTRUCTURE - R.P.E.Q: 8 5 9 1			
DESIGN	Std Dwgs WG	DATE	April '09
DRAWN	CPD - P&D	DATE	April '09
CHECKED	I. Condrik	DATE	Dec '10
DRAWING FILENAME	BSD-4103.dwg		
ASSOCIATED PLANS	SUPERSEDES UMS-600-042		

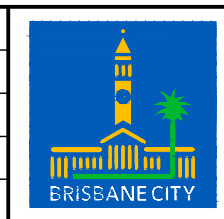

BRISBANE CITY COUNCIL STANDARD DRAWING	
SCALE NOT TO SCALE	
DWG No. BSD-4103	
ORIGINAL SIZE A3	REVISION A