

**ELEVATION**  
SCALE 1:20

| MEMBER SCHEDULE |                                 |
|-----------------|---------------------------------|
| ELEMENT         | MEMBER                          |
| FENCE POST      | 60.3x3.6 CHS (50NB BLUE BAND)   |
| GATE POST       | 114.3x4.5 CHS (100NB BLUE BAND) |
| RAILS           | 48.3x3.2 CHS (40NB BLUE BAND)   |

**SPECIAL NOTE**  
THE PURPOSE OF THIS STANDARD IS TO PROVIDE A BARRIER RESTRICTING ACCESS. IT IS NOT APPLICABLE FOR PROVIDING EDGE PROTECTION WHERE THERE IS RISK OF INJURY FROM A FALL GREATER THAN 1m. THIS INCLUDES LOCATIONS SUCH AS CULVERTS, BRIDGE CROSSINGS AND LARGE RETAINING WALLS.

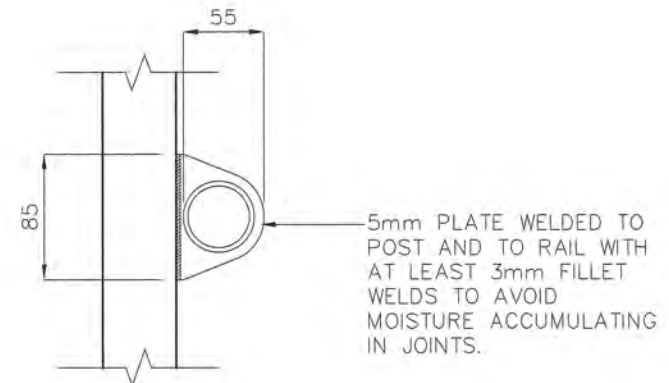

**SECTION**  
SCALE 1:5

**GENERAL NOTES**

- ENSURE THAT WORK IS IN ACCORDANCE WITH BRISBANE CITY COUNCIL ENVIRONMENTAL BEST PRACTICE NOTES.
- SITE SETOUT TO BE VERIFIED BY SUPERINTENDENT OR LANDSCAPE ARCHITECT PRIOR TO THE COMMENCEMENT OF CONSTRUCTION WORKS.
- VERIFY LOCATION OF ALL SERVICES AND EASEMENTS PRIOR TO THE COMMENCEMENT OF WORKS.
- WRITTEN DIMENSIONS TAKE PRECEDENCE OVER SCALED DISTANCES.
- VERIFY ALL DIMENSIONS ON SITE PRIOR TO CONSTRUCTION.
- FOOTINGS HAVE BEEN DESIGNED ON THE ASSUMPTION THAT THE MINIMUM ALLOWABLE BEARING CAPACITY OF SOIL IS 100kPa.
- IN EACH CASE ENGINEERING CERTIFICATION AND MODIFICATION AS NECESSARY WILL BE REQUIRED FOR PARTICULAR SOIL AND SITE CONDITIONS.
- THE COPYRIGHT OF THIS DRAWING REMAINS THE PROPERTY OF THE BRISBANE CITY COUNCIL.
- DIMENSIONS IN MILLIMETRES (UNO)

**STEEL NOTES**

1. WHERE FENCE IS FOR USE IN A NON-MARINE ENVIRONMENT (MORE THAN 1KM FROM THE FORESHORE), THE FOLLOWING PROTECTION TREATMENT IS REQUIRED:  
HOT DIP GALVANISING:
  - FERROUS OPEN SECTIONS TO AS4791
  - FERROUS HOLLOW SECTIONS TO AS4792
 STEEL WORK
  - MAY BE POWDERCOATED TO AS4506 - COLOUR 'MATT BLACK' IF REQUIRED.
2. WHERE FENCE IS REQUIRED FOR USE WITHIN MARINE ENVIRONMENT (UP TO 1km FROM THE FORESHORE), THE FOLLOWING PROTECTION TREATMENT IS REQUIRED:  
HOT DIP GALVANISING:
  - 85 MICRONS (600G/M<sup>2</sup>) MIN;
  - SWEEP ABRASIVE BLAST;
 STEELWORK FIRST COAT:
  - EPOXY PRIMER 75 MICRONS MIN;
 STEELWORK SECOND COAT:
  - TWO PACK ACRYLIC OR POLYURETHANE GLOSS 75 MICRONS MIN;
3. PAINT SYSTEMS TO BE IN ACCORDANCE WITH AS2312 AND IS DESIGNATED HDG600P6.
4. ALL STEEL TUBE TO AS/NZ1163.
5. POSTS TO BE VERTICAL.
6. ALL RAILS ARE SWAGED AND WELDED. SWAGES TO BE ON INSIDE OF FENCE AND NOT FACING PUBLIC ROADS, ETC).
7. ALL JOINTS TO BE FULLY WELDED. WELDS TO BE 5 THICK C.F.W (CONTINUOUS FILLET WELDS) TO AS554.1 WITH COLD GALVANISING TREATMENT TO COMPLETED WELDS.
8. PREFERRED COLD GALVANISING TREATMENT FOR IN-SITU WELDS, CUT ENDS OR OTHER BARE STEEL IS TO APPLY 2 COATS OF INORGANIC ZINC PRIMER APPLIED BY BRUSH.
9. STANDARD COUPLINGS (MONOWILLS, SENTAUER JOINTS, KEE-KLAMP, SWAGED JOINTS OR SIMILAR) FOR POST TO RAIL CONNECTIONS MAY BE USED AS AN ALTERNATIVE TO WELDS WHERE APPROVED. 11° MAX REFLECTION FROM HORIZONTAL FOR STANDARD COUPLINGS. FOR ANGLES GREATER THAN 11°, SPECIALIST COUPLINGS MAY BE USED UPON APPROVAL FROM COUNCIL.

|   |           |            |            |                  |               |      |         |   |   |               |
|---|-----------|------------|------------|------------------|---------------|------|---------|---|---|---------------|
| DRAWING AUTHORISED FOR PUBLICATION  |           |            |            | DESIGN           | CPO - P&D     | DATE | DEC '14 |  | <b>BRISBANE CITY COUNCIL STANDARD DRAWING</b> |               |
| ASSET ENGINEERING MANAGER<br>STRATEGIC ASSET MANAGEMENT                           |           |            |            | DRAWN            | CPO - P&D     | DATE | DEC '14 |   | SCALE<br>AS SHOWN                             |               |
| DESIGN APPROVED<br><i>E. Wood</i>   |           |            |            | CHECKED          | BI - FSG - AS | DATE | DEC '14 |   | DWG No.<br><b>BSD-7008</b>                    |               |
| SENIOR CO-ORDINATOR NATURAL ENVIRONMENT<br>ASSET SERVICES/BRISBANE INFRASTRUCTURE |           |            |            | DRAWING FILENAME | BSD-7008.dwg  |      |         |   | ORIGINAL SIZE<br>A3                           |               |
| ISSUE   | AMENDMENT | DRAWN DATE | CHK'D DATE | APPR'D DATE      |               |      |         | <b>FENCE -<br/>NATURAL AREA -<br/>THREE RAIL</b>                                      |   | REVISION<br>A |