

STANDARDS

DESIGNED IN ACCORDANCE WITH, AND FABRICATION TO MEET THE FOLLOWING STANDARDS:

- PARTIALLY COMPLIANT WITH AS1428.2:1992, CLAUSE 27.2 SEATING IN PEDESTRIAN AREAS.
- AS1627.4 METAL FINISHING – PREPARATION AND PRE-TREATMENT OF SURFACES – ABRASIVE BLAST CLEANING OF STEEL.
- AS2312:2002/AMDT 1:2004, GUIDE TO PROTECTION OF IRON AND STEEL AGAINST EXTERIOR ATMOSPHERIC CORROSION, 1994.
- GUIDE TO ENGINEERING PRACTICE, 'PEDESTRIANS', PART 13, AUSTRROADS.
- AS2796.3:1999, TIMBER FOR FURNITURE COMPONENTS.
- AS1604.1–2005, SPECIFICATION FOR PRESERVATIVE TREATMENT, SAWN AND ROUND TIMBER.
- AS4506 –2005, METAL FINISHING– THERMOSET POWDER COATINGS.
- AS4680:2006, HOT DIP GALVANISING.
- POWDERCOATING TO BE IN ACCORDANCE TO AS4506–2005 EXTERNAL EXPOSURE STANDARD WITH PRE-TREATMENT SAND BLAST, ZINC PHOSPHATE, ETC.
- WOOD TREATMENT – IN ACCORDANCE WITH AS1604.1 HAZARD CLASSIFICATION H3 (EXTERIOR ABOVE GROUND) AND AS2796.3 (TIMBER FOR FURNITURE COMPONENTS.)

NOTES

- WELDING TO BE ACCORDANCE TO AS1554.1 CAT GP WELDING, ALL SHARP EDGES & BURRS REMOVED.
- PART SHOULD BE SUPPLIED CLEAN AND FREE FROM MARKS, BURRS, SCUFFS, DISTORTION AND WARPAGE.
- ENSURE ANTI-SEIZE IS ON ALL NUTS AND BOLTS PRIOR TO ASSEMBLY.
- DRAWING TO AS1100 DRAWING STANDARDS.
- 316 S.S AND 316 S.S FASTENERS TO BE USED THROUGHOUT FOR COASTAL INSTALLATIONS OR ANY ENVIRONMENT WITH HIGH CORROSION.
- ALL TOLERANCES $\pm 1.5\text{mm}$ UNLESS OTHERWISE SPECIFIED.
- THIS IS A LEFT HAND (MIRRORED) VERSION OF PART 'SEAT OUTER SPINE (RIGHT)' – REFER TO DRAWING BSD-7201 FOR FABRICATION AND DIMENSION DETAILS.

MATERIAL

- MATERIAL: MILD STEEL
- COLOUR: DULUX 'METROPOLIS STORM PEARL' OR APPROVED EQUIVALENT
- FINISH: GALVANISED AND POWDER COATED

STRUCTURAL DESIGN REVIEWED AND CERTIFIED FOR ISSUE

NAME: B.C. PLANT _____ RPEQ: 8807

SIGNATURE: ON ORIGINAL _____ DATE: 28/6/12

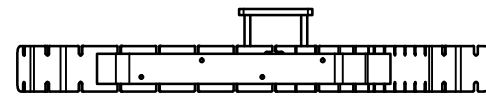

TOP VIEW

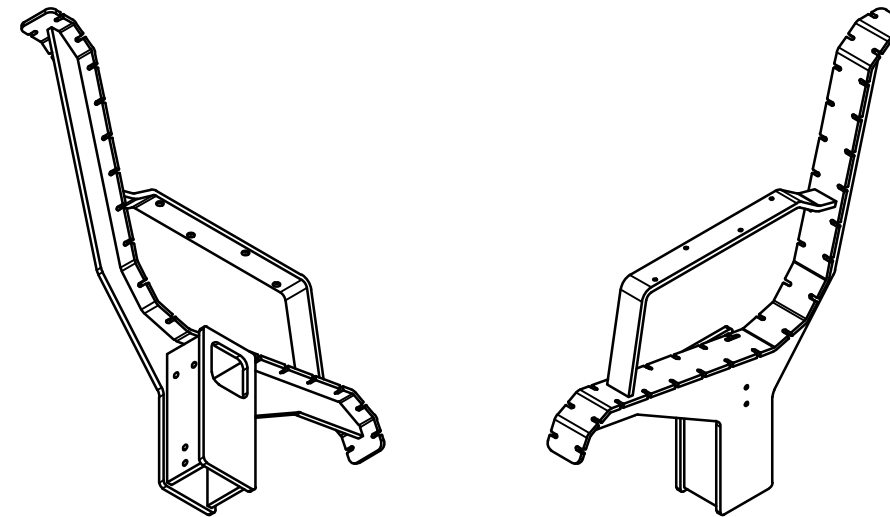

PICTORIAL VIEWS

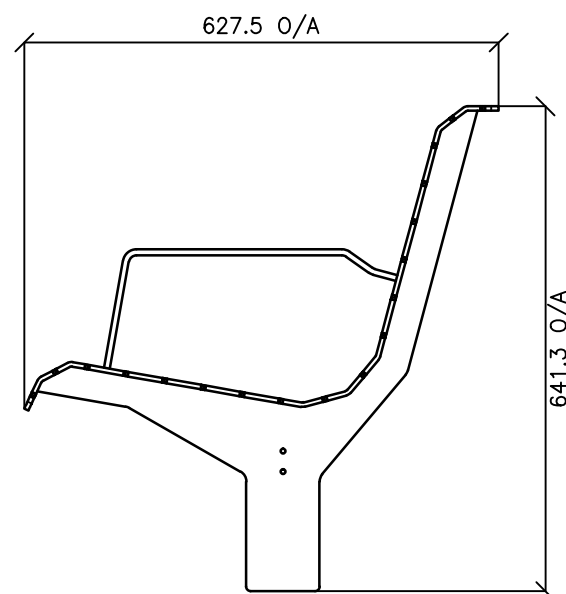

RIGHT SIDE VIEW

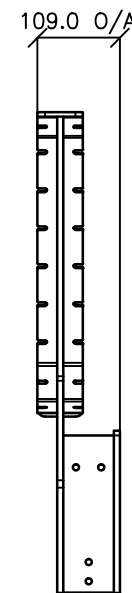

BACK VIEW

LEFT HAND (MIRRORED) VERSION OF 'OUTER SPINE (RIGHT)' REFER TO DRAWING BSD-7201 FOR FABRICATION AND DIMENSION DETAILS.

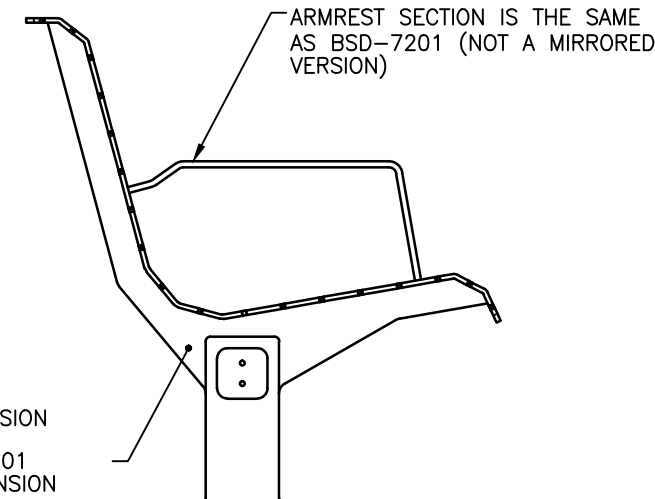

LEFT SIDE VIEW

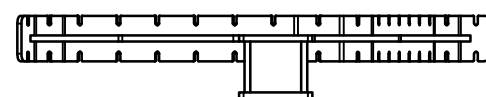

BOTTOM VIEW

ISSUE	AMENDMENT	DRAWN DATE	CHK'D DATE	APPR'D DATE	DRAWING AUTHORITY	DESIGN	FORMZOO DESIGN	DATE	JUN '12		BRISBANE CITY COUNCIL STANDARD DRAWING		
C	Colour Finish Requirements Updated (Material Notes)	MAY '17	MAY '17	MAY '17	ASSET ENGINEERING MANAGER STRATEGIC ASSET MANAGEMENT	DRAWN	AB	DATE	JUN '12		SCALE	NOT TO SCALE	
B	Drawing Title Amended	FEB '16	JUL '16	JUL '16	DESIGN APPROVED	CHECKED	VM	DATE	APR '13		DWG No.	BSD-7201	
A	Drawing Converted from UMS Series April 2014	APR '14	APR '14	APR '14	VICKI MARTIN SIGNATURE ON ORIGINAL	DRAWING FILENAME	BSD-7201 (B) Standard seat - Outer spine (left) - Sheet 5 of 10.dwg				ORIGINAL SIZE	REVISION	A3
					PRINCIPAL PLANNING OFFICER URBAN DESIGN	ASSOCIATED PLANS	SUPERSEDES UMS-563-5						