

STANDARDS

DESIGNED IN ACCORDANCE WITH, AND FABRICATION TO MEET THE FOLLOWING STANDARDS:

- AS1627.4 METAL FINISHING – PREPARATION AND PRE-TREATMENT OF SURFACES – ABRASIVE BLAST CLEANING OF STEEL.
- AS2312:2002/AMDT 1:2004, GUIDE TO PROTECTION OF IRON AND STEEL AGAINST EXTERIOR ATMOSPHERIC CORROSION, 1994.
- GUIDE TO ENGINEERING PRACTICE, 'PEDESTRIANS', PART 13, AUSTRoadS.
- AS2796.3:1999, TIMBER FOR FURNITURE COMPONENTS.
- AS1604.1-2005, SPECIFICATION FOR PRESERVATIVE TREATMENT, SAWN AND ROUND TIMBER.
- AS4506 –2005, METAL FINISHING– THERMOSET POWDER COATINGS.
- AS4680:2006, HOT DIP GALVANISING.
- POWDERCOATING TO BE IN ACCORDANCE TO AS4506-2005 EXTERNAL EXPOSURE STANDARD WITH PRE-TREATMENT SAND BLAST, ZINC PHOSPHATE, ETC.
- WOOD TREATMENT – IN ACCORDANCE WITH AS1604.1 HAZARD CLASSIFICATION H3 (EXTERIOR ABOVE GROUND) AND AS2796.3 (TIMBER FOR FURNITURE COMPONENTS.)

NOTES

- WELDING TO BE ACCORDANCE TO AS1554.1 CAT GP WELDING, ALL SHARP EDGES & BURRS REMOVED.
- PART SHOULD BE SUPPLIED CLEAN AND FREE FROM MARKS, BURRS, SCUFFS, DISTORTION AND WARPAGE.
- ENSURE ANTI-SEIZE IS ON ALL NUTS AND BOLTS PRIOR TO ASSEMBLY.
- DRAWING TO AS1100 DRAWING STANDARDS.
- 316 S.S AND 316 S.S FASTENERS TO BE USED THROUGHOUT FOR COASTAL INSTALLATIONS OR ANY ENVIRONMENT WITH HIGH CORROSION.
- ALL TOLERANCES ± 1.5mm UNLESS OTHERWISE SPECIFIED.
- THIS IS A LEFT HAND (MIRRORED) VERSION OF PART 'BENCH OUTER SPINE (RIGHT)' – REFER TO DRAWING BSD-7203 FOR FABRICATION AND DIMENSION DETAILS.

MATERIAL

- MATERIAL: MILD STEEL
- COLOUR: DULUX 'METROPOLIS STORM PEARL' OR APPROVED EQUIVALENT
- FINISH: GALVANISED AND POWDER COATED

STRUCTURAL DESIGN REVIEWED AND CERTIFIED FOR ISSUE
 NAME: B.C. PLANT _____ RPEQ: 8807 _____
 SIGNATURE: ON ORIGINAL _____ DATE: 28/6/12

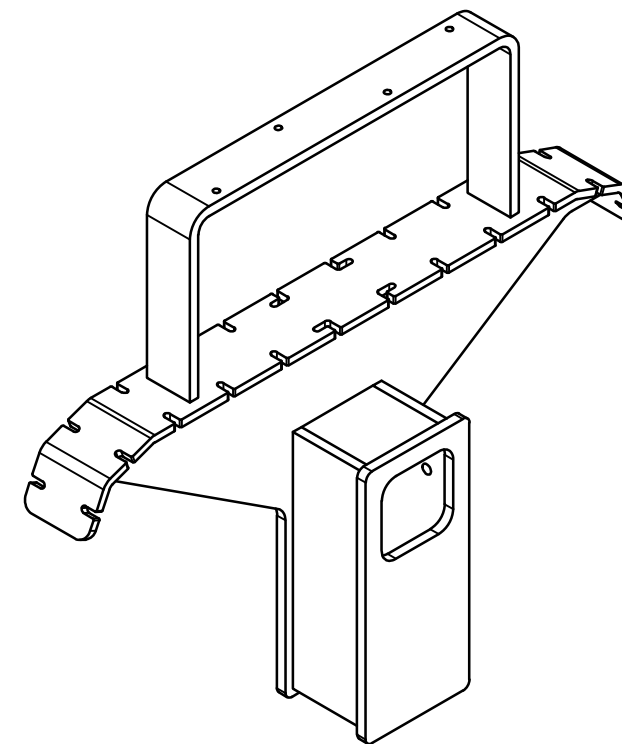

PICTORIAL VIEW

ARMREST SECTION IS THE SAME AS BSD-7203 (NOT A MIRRORED VERSION)

LEFT HAND (MIRRORED) VERSION OF 'OUTER SPINE (RIGHT)'. REFER TO DRAWING BSD-7203 FOR FABRICATION AND DIMENSION DETAILS.

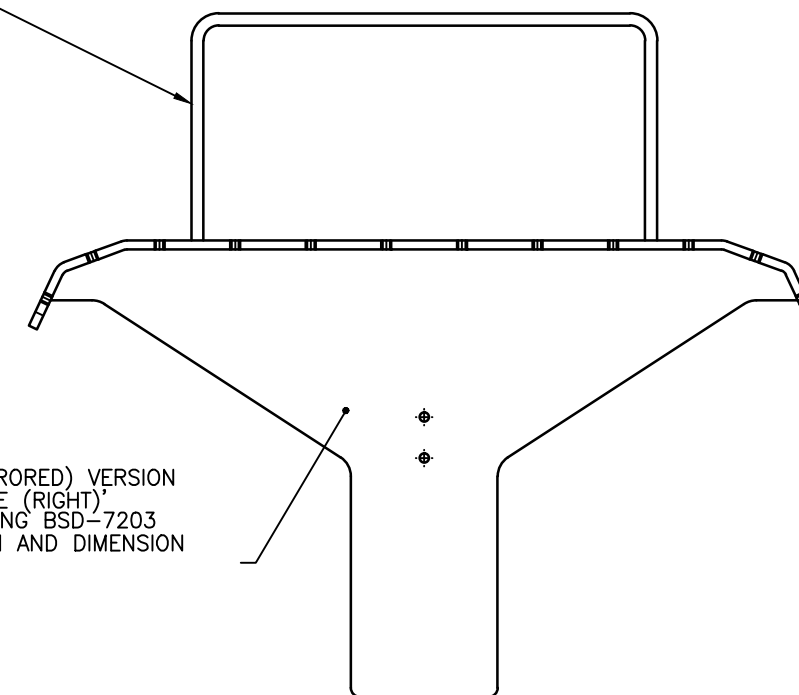

LEFT SIDE VIEW

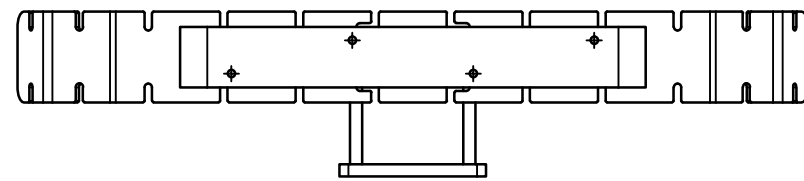

TOP VIEW

522.9 O/A

99.0 O/A

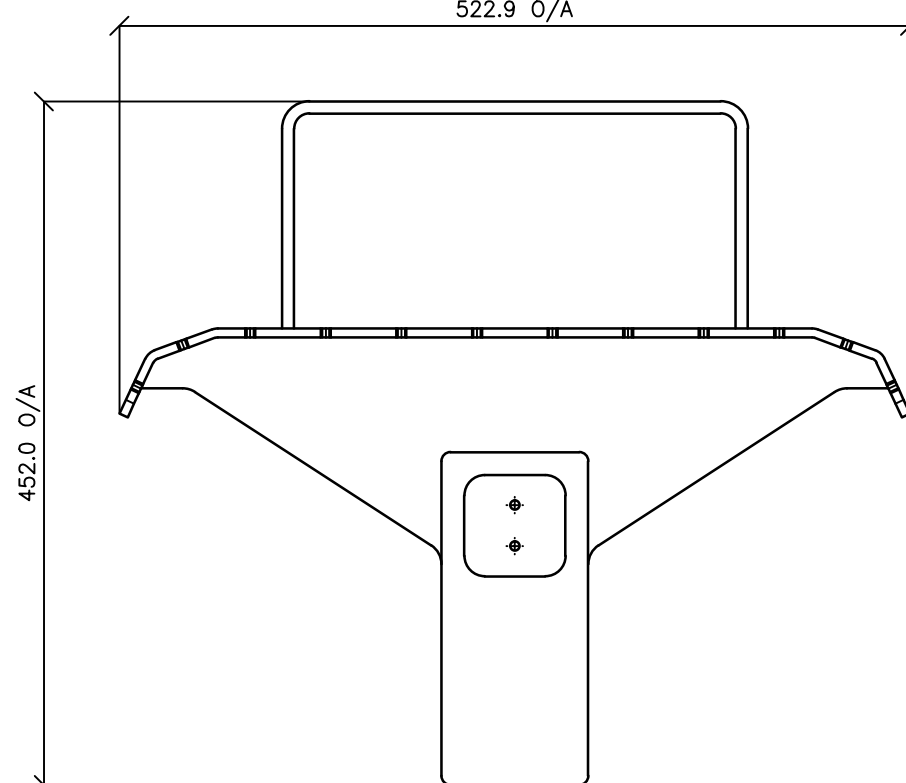

RIGHT SIDE VIEW

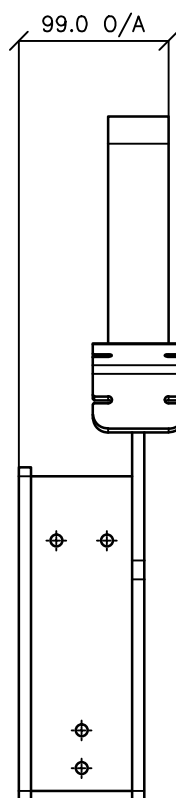

BACK VIEW

452.0 O/A

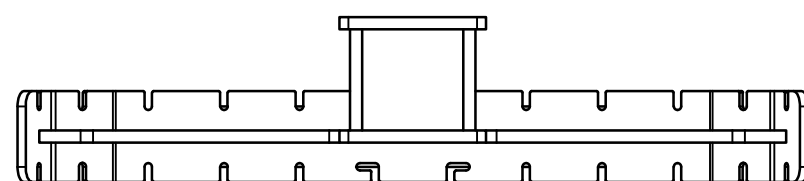

BOTTOM VIEW

ISSUE	AMENDMENT	DRAWN DATE	CHK'D DATE	APPR'D DATE
C	Colour Finish Requirements Updated (Material Notes)	MAY '17	MAY '17	MAY '17
B	Drawing Title Amended	FEB '16	JUL '16	JUL '16
A	Drawing Converted from UMS Series April 2014	APR '14	APR '14	APR '14

DRAWING AUTHORISED FOR PUBLICATION INGA CONDRIK AUTHORISED 15/04/2014			
DESIGN	FORMZOO DESIGN	DATE	JUN '12
DRAWN	AB	DATE	JUN '12
CHECKED	VM	DATE	APR '13
DRAWING FILENAME	BSD-7203 (B) Bench - Outer spine (left) - Sheet 5 of 10.dwg		
ASSOCIATED PLANS	SUPERSEDES UMS-564-5		

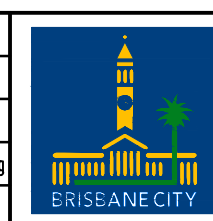

BRISBANE CITY COUNCIL STANDARD DRAWING	
BENCH OUTER SPINE (LEFT) SHEET 5 OF 10	
SCALE	NOT TO SCALE
DWG No.	BSD-7203
ORIGINAL SIZE	A3
REVISION	C