

**PLAN**  
SCALE: 1:20

**ELEVATION**  
SCALE: 1:20

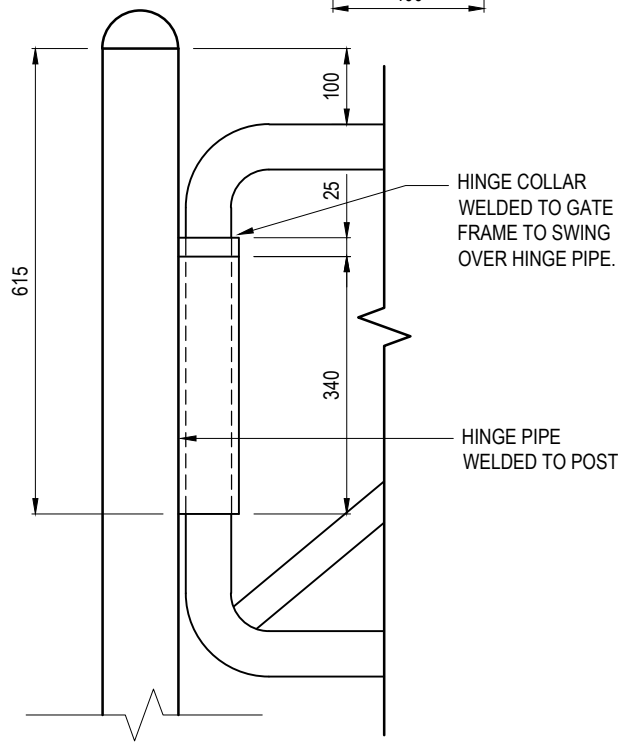

**HINGE DETAIL**  
SCALE: 1:10

**GENERAL NOTES**

- G1. ENSURE THAT WORK IS IN ACCORDANCE WITH BRISBANE CITY COUNCIL ENVIRONMENTAL BEST PRACTICE NOTES.
- G2. SITE SETOUT TO BE VERIFIED BY SUPERINTENDENT OR LANDSCAPE ARCHITECT PRIOR TO THE COMMENCEMENT OF CONSTRUCTION WORKS.
- G3. VERIFY LOCATION OF ALL SERVICES AND EASEMENTS PRIOR TO THE COMMENCEMENT OF WORKS.
- G4. WRITTEN DIMENSIONS TAKE PRECEDENCE OVER SCALED DISTANCES.
- G5. VERIFY ALL DIMENSIONS ON SITE PRIOR TO CONSTRUCTION.
- G6. STRUCTURES HAVE BEEN DESIGNED ON THE ASSUMPTION THAT THE MINIMUM ALLOWABLE BEARING CAPACITY FOR SOIL IS 100KPa AND TERRAIN CATEGORY = 2.5.
- G7. IN EACH CASE ENGINEERING CERTIFICATION AND MODIFICATION AS NECESSARY WILL BE REQUIRED FOR PARTICULAR SOIL AND SITE CONDITIONS.
- G8. THE COPYRIGHT OF THIS DRAWING REMAINS THE PROPERTY OF THE BRISBANE CITY COUNCIL.
- G9. REFER TO BSD - 7059 FOR LOCKING BOX TYPE AND DETAILS.

**NOTES**

- N1. WHERE STANDARD IS FOR USE IN A NON-MARINE ENVIRONMENT (UP TO 1km FROM THE FORESHORE), THE FOLLOWING PROTECTION TREATMENT IS REQUIRED:
  - HOT DIP GALVANISING: FERROUS OPEN SECTIONS TO AS4791.
  - FERROUS HOLLOW SECTIONS TO AS4792.
  - STEEL WORK TO BE POWDERCOATED TO AS4506 - COLOUR 'YELLOW'.
- N2. WHERE STANDARD IS REQUIRED FOR USE WITHIN MARINE ENVIRONMENT, THE FOLLOWING PROTECTION TREATMENT IS REQUIRED:
  - STEELWORK HOT DIP GALVANISING: 85 MICRONS (600g/m<sup>2</sup>) MIN;
  - SWEEP ABRASIVE BLAST;
  - STEELWORK FIRST COAT: EPOXY PRIMER 75 MICRONS MIN;
  - STEELWORK SECOND COAT: TWO PACK ACRYLIC OR POLYURETHANE GLOSS 75 MICRONS MIN;
- N3. PAINT SYSTEMS TO BE IN ACCORDANCE WITH AS2312 AND IS DESIGNATED HDG600P6 AND HDG600P.
- N4. GATE POSTS TO BE 90NB GALVANISED STEEL TUBE TO AS/NZ1163.
- N5. RAILS TO BE 50OD (60.3OD), 3.6mm THICK GALVANISED STEEL TUBE TO AS/NZ1163.
- N6. POSTS TO BE VERTICAL.
- N7. ALL RAILS ARE SWAGED AND WELDED.
- N8. ALL JOINTS TO BE FULLY WELDED. WELDS TO BE 5 THICK C.F.W (CONTINUOUS FILLET WELDS) TO AS/NZS1554.1.
- N9. GATE AND ADJACENT POSTS TO BE POWDER COATED 'YELLOW'.

ISSUE	AMENDMENT	DRAWN DATE	CHK'D DATE	APPR'D DATE
B	Note Nymbers Added/Updated, AS/NZS Reference in Note N8 Corrected	SEP '18	APR '19	APR '19
A	ORIGINAL ISSUE	DEC '14	DEC '14	DEC '14

**DRAWING AUTHORISED FOR PUBLICATION**  
 Inga Condric  
 2015.06.04 14:37:10+10'00'  
 pof ASSET ENGINEERING MANAGER  
 STRATEGIC ASSET MANAGEMENT  
**DESIGN APPROVED**  
 C.Wood  
 SENIOR CO-ORDINATOR NATURAL ENVIRONMENT  
 ASSET SERVICES/BRISBANE INFRASTRUCTURE

DESIGN	CPD - P&D	DATE	DEC '14
DRAWN	CPD - P&D	DATE	DEC '14
CHECKED	BI - FSG - AS	DATE	DEC '14
DRAWING FILENAME	BSD-7057 (B) Vehicle access gate - Natural area - Medium duty.dwg		
ASSOCIATED PLANS			

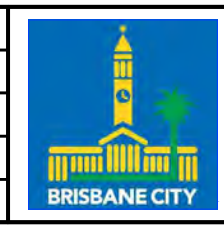

**BRISBANE CITY COUNCIL STANDARD DRAWING**

VEHICLE ACCESS GATE  
NATURAL AREA  
MEDIUM DUTY

SCALE AS SHOWN  
DWG No. BSD-7057  
ORIGINAL SIZE A3 REVISION B

PRELIMINARY PRINT  
FOR DISCUSSION PURPOSES ONLY

PRELIMINARY PRINT  
FOR DISCUSSION PURPOSES ONLY

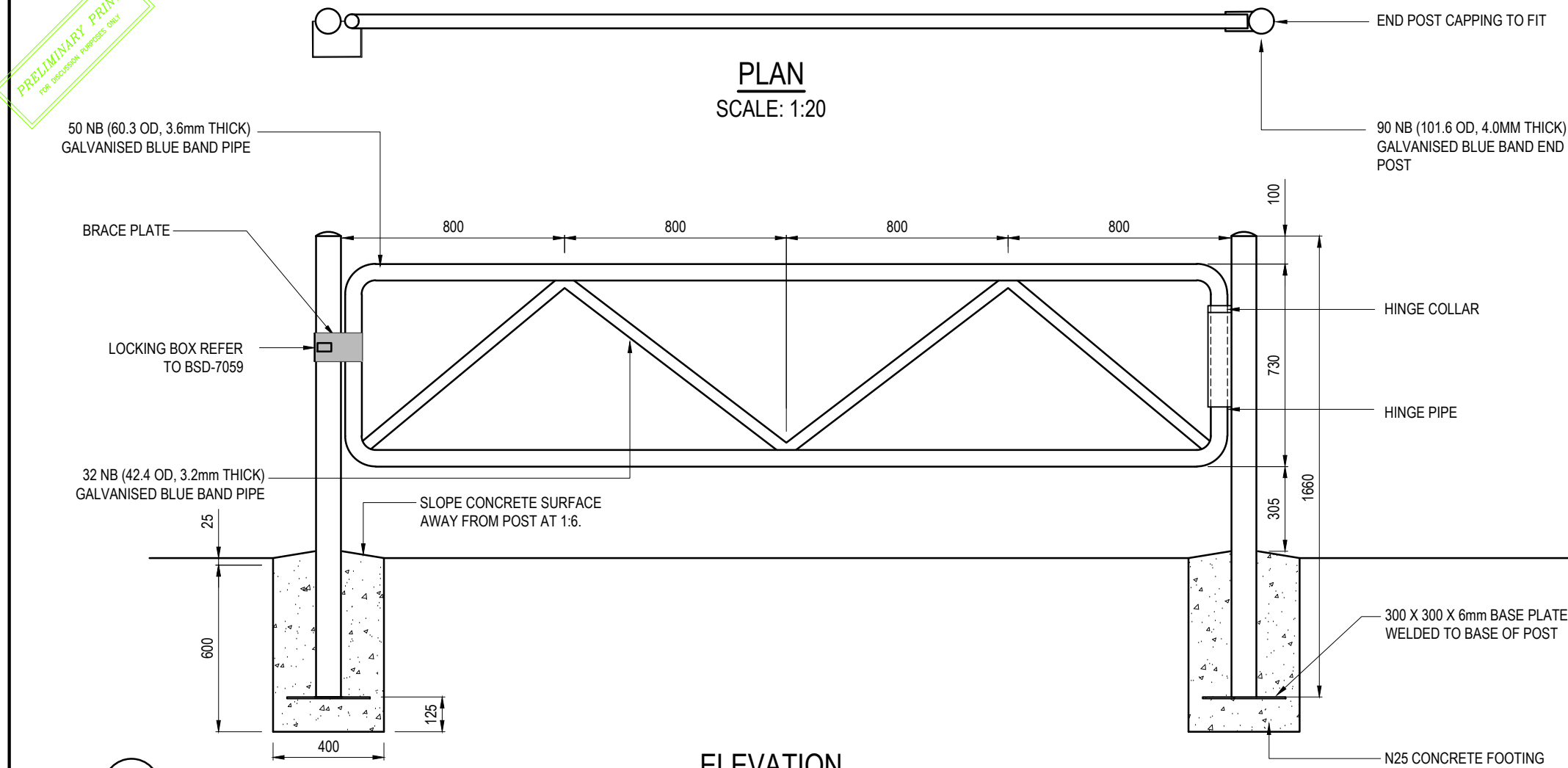

**GENERAL NOTES**

- G1. ENSURE THAT WORK IS IN ACCORDANCE WITH BRISBANE CITY COUNCIL ENVIRONMENTAL BEST PRACTICE NOTES.
- G2. SITE SETOUT TO BE VERIFIED BY SUPERINTENDENT OR LANDSCAPE ARCHITECT PRIOR TO THE COMMENCEMENT OF CONSTRUCTION WORKS.
- G3. VERIFY LOCATION OF ALL SERVICES AND EASEMENTS PRIOR TO THE COMMENCEMENT OF WORKS.
- G4. WRITTEN DIMENSIONS TAKE PRECEDENCE OVER SCALED DISTANCES.
- G5. VERIFY ALL DIMENSIONS ON SITE PRIOR TO CONSTRUCTION.
- G6. STRUCTURES HAVE BEEN DESIGNED ON THE ASSUMPTION THAT THE MINIMUM ALLOWABLE BEARING CAPACITY FOR SOIL IS 100KPa AND TERRAIN CATEGORY = 2.5.
- G7. IN EACH CASE ENGINEERING CERTIFICATION AND MODIFICATION AS NECESSARY WILL BE REQUIRED FOR PARTICULAR SOIL AND SITE CONDITIONS.
- G8. THE COPYRIGHT OF THIS DRAWING REMAINS THE PROPERTY OF THE BRISBANE CITY COUNCIL.
- G9. REFER TO BSD - 7059 FOR LOCKING BOX TYPE AND DETAILS.

**NOTES**

- N1. WHERE STANDARD IS FOR USE IN A NON-MARINE ENVIRONMENT (UP TO 1km FROM THE FORESHORE), THE FOLLOWING PROTECTION TREATMENT IS REQUIRED:
  - HOT DIP GALVANISING: FERROUS OPEN SECTIONS TO AS4791.
  - FERROUS HOLLOW SECTIONS TO AS4792.
  - STEEL WORK TO BE POWDERCOATED TO AS4506 - COLOUR 'YELLOW'.
- N2. WHERE STANDARD IS REQUIRED FOR USE WITHIN MARINE ENVIRONMENT, THE FOLLOWING PROTECTION TREATMENT IS REQUIRED:
  - STEELWORK HOT DIP GALVANISING: 85 MICRONS (600g/m<sup>2</sup>) MIN;
  - SWEEP ABRASIVE BLAST;
  - STEELWORK FIRST COAT: EPOXY PRIMER 75 MICRONS MIN;
  - STEELWORK SECOND COAT: TWO PACK ACRYLIC OR POLYURETHANE GLOSS 75 MICRONS MIN;
- N3. PAINT SYSTEMS TO BE IN ACCORDANCE WITH AS2312 AND IS DESIGNATED HDG600P6 AND HDG600P.
- N4. GATE POSTS TO BE 90NB GALVANISED STEEL TUBE TO AS/NZ1163.
- N5. RAILS TO BE 50OD (60.3OD), 3.6mm THICK GALVANISED STEEL TUBE TO AS/NZ1163.
- N6. POSTS TO BE VERTICAL.
- N7. ALL RAILS ARE SWAGED AND WELDED.
- N8. ALL JOINTS TO BE FULLY WELDED. WELDS TO BE 5 THICK C.F.W (CONTINUOUS FILLET WELDS) TO AS/NZS1554.1.
- N9. GATE AND ADJACENT POSTS TO BE POWDER COATED 'YELLOW'.

**ELEVATION**  
SCALE: 1:20

PRELIMINARY PRINT  
FOR DISCUSSION PURPOSES ONLY

**CITY PLAN  
MINOR AMENDMENT H  
MARKED CHANGES**

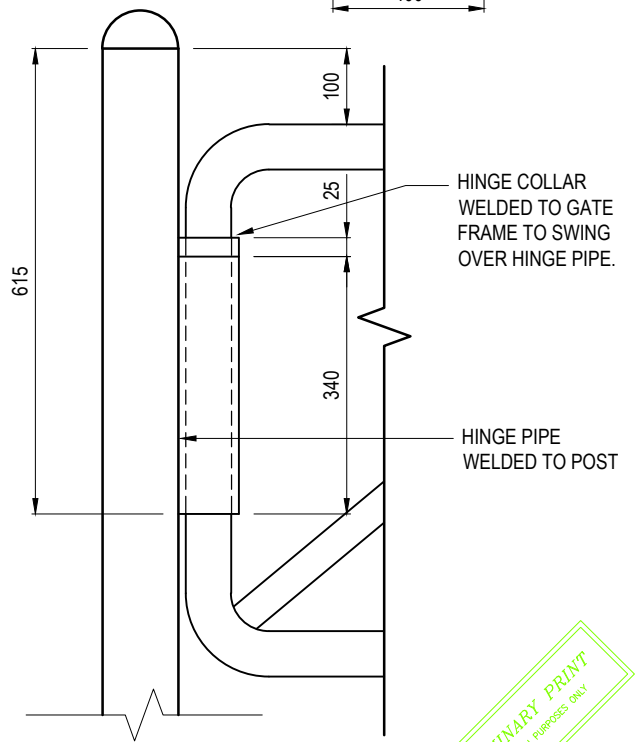

**HINGE DETAIL**  
SCALE: 1:10

PRELIMINARY PRINT  
FOR DISCUSSION PURPOSES ONLY

PRELIMINARY PRINT  
FOR DISCUSSION PURPOSES ONLY

ISSUE	AMENDMENT	DRAWN DATE	CHK'D DATE	APPR'D DATE
B	Note Numbers Added/Updated, AS/NZS Reference in Note N8 Corrected	SEP '18	APR '19	APR '19
A	ORIGINAL ISSUE	DEC '14	DEC '14	DEC '14

<b>DRAWING AUTHORISED FOR PUBLICATION</b>			
Inga Condric 2015.06.04 14:37:10+10'00'	DESIGN	CPD - P&D	DATE DEC '14
for ASSET ENGINEERING MANAGER STRATEGIC ASSET MANAGEMENT	DRAWN	CPD - P&D	DATE DEC '14
<b>DESIGN APPROVED</b>	CHECKED	BI - FSG - AS	DATE DEC '14
C. Wood	DRAWING FILENAME	BSD-7057 (B) Vehicle access gate - Natural area - Medium duty.dwg	
SENIOR CO-ORDINATOR NATURAL ENVIRONMENT ASSET SERVICES/BRISBANE INFRASTRUCTURE	ASSOCIATED PLANS		



<b>BRISBANE CITY COUNCIL STANDARD DRAWING</b>	
VEHICLE ACCESS GATE NATURAL AREA MEDIUM DUTY	
SCALE AS SHOWN	DWG No. <b>BSD-7057</b>
ORIGINAL SIZE A3	REVISION B

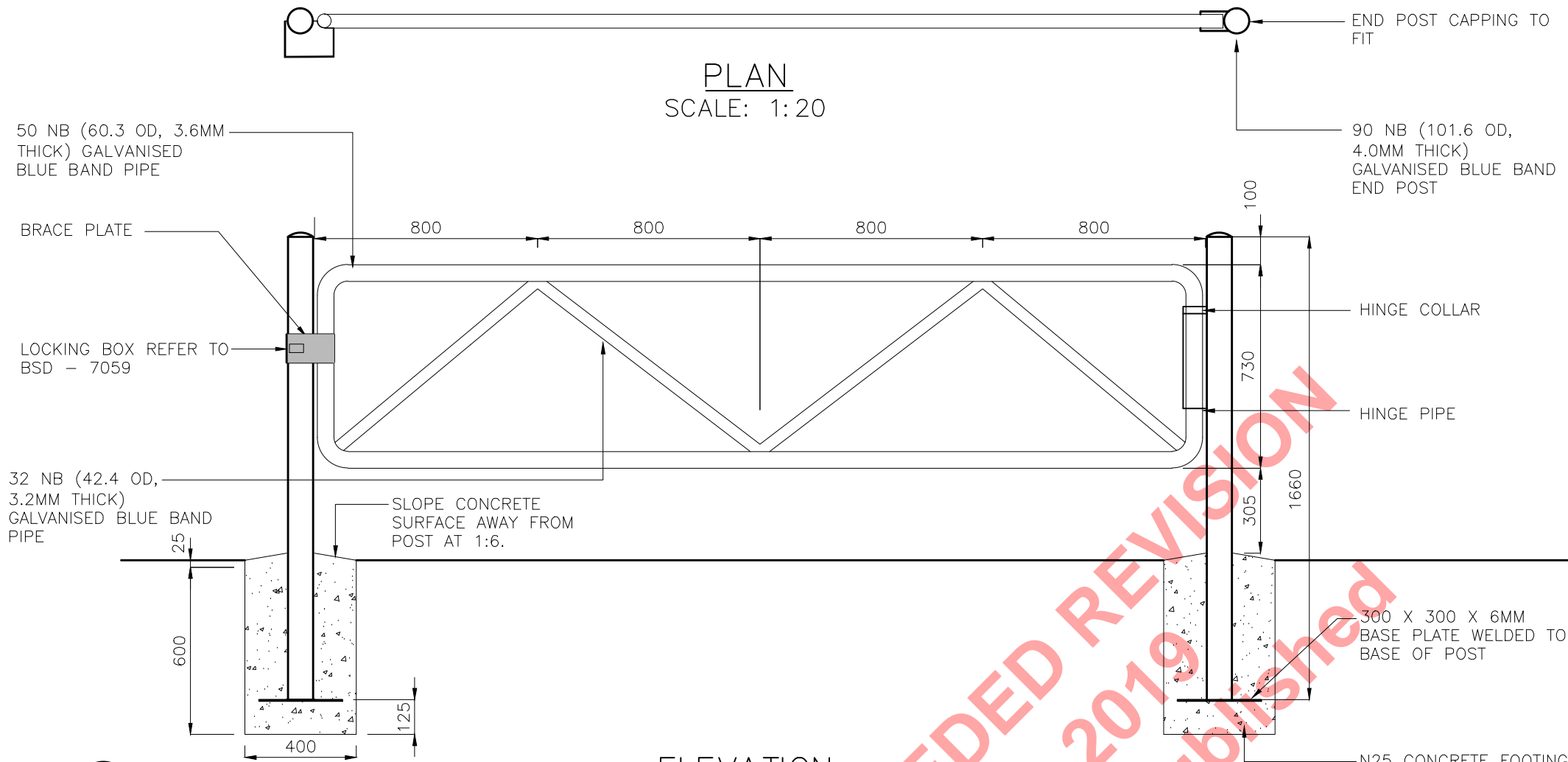

PLAN  
SCALE: 1:20

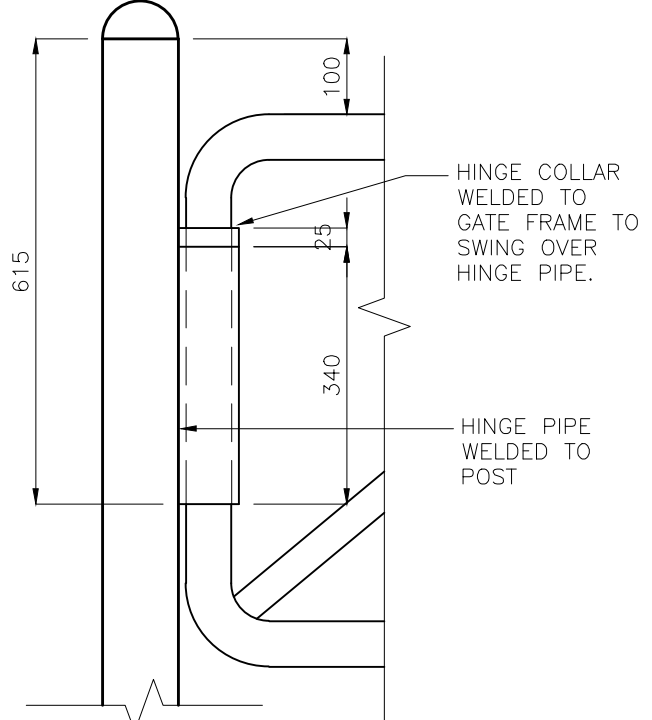

ELEVATION  
SCALE: 1:20

HINGE DETAIL  
SCALE: 1:10

**GENERAL NOTES**

- ENSURE THAT WORK IS IN ACCORDANCE WITH BRISBANE CITY COUNCIL ENVIRONMENTAL BEST PRACTICE NOTES.
- SITE SETOUT TO BE VERIFIED BY SUPERINTENDENT OR LANDSCAPE ARCHITECT PRIOR TO THE COMMENCEMENT OF CONSTRUCTION WORKS.
- VERIFY LOCATION OF ALL SERVICES AND EASEMENTS PRIOR TO THE COMMENCEMENT OF WORKS.
- WRITTEN DIMENSIONS TAKE PRECEDENCE OVER SCALED DISTANCES.
- VERIFY ALL DIMENSIONS ON SITE PRIOR TO CONSTRUCTION.
- STRUCTURES HAVE BEEN DESIGNED ON THE ASSUMPTION THAT THE MINIMUM ALLOWABLE BEARING CAPACITY FOR SOIL IS 100KPA AND TERRAIN CATEGORY = 2.5.
- IN EACH CASE ENGINEERING CERTIFICATION AND MODIFICATION AS NECESSARY WILL BE REQUIRED FOR PARTICULAR SOIL AND SITE CONDITIONS.
- THE COPYRIGHT OF THIS DRAWING REMAINS THE PROPERTY OF THE BRISBANE CITY COUNCIL.
- REFER TO BSD - 7059 FOR LOCKING BOX TYPE AND DETAILS.

**NOTES**

1. WHERE STANDARD IS FOR USE IN A NON-MARINE ENVIRONMENT (UP TO 1KM FROM THE FORESHORE), THE FOLLOWING PROTECTION TREATMENT IS REQUIRED:
  - HOT DIP GALVANISING: FERROUS OPEN SECTIONS TO AS4791
  - FERROUS HOLLOW SECTIONS TO AS4792
  - STEEL WORK TO BE POWDERCOATED TO AS4506 - COLOUR 'YELLOW'.
2. WHERE STANDARD IS REQUIRED FOR USE WITHIN MARINE ENVIRONMENT, THE FOLLOWING PROTECTION TREATMENT IS REQUIRED:
  - STEELWORK HOT DIP GALVANISING: 85 MICRONS (600G/M<sup>2</sup>) MIN;
  - SWEEP ABRASIVE BLAST;
  - STEELWORK FIRST COAT: EPOXY PRIMER 75 MICRONS MIN;
  - STEELWORK SECOND COAT: TWO PACK ACRYLIC OR POLYURETHANE GLOSS 75 MICRONS MIN;
3. PAINT SYSTEMS TO BE IN ACCORDANCE WITH AS2312 AND IS DESIGNATED HDG600P6 AND HDG600P
4. GATE POSTS TO BE 90NB GALVANISED STEEL TUBE TO AS/NZ1163.
5. RAILS TO BE 500D (60.30D), 3.6mm THICK GALVANISED STEEL TUBE TO AS/NZ1163.
6. POSTS TO BE VERTICAL.
7. ALL RAILS ARE SWAGED AND WELDED.
8. ALL JOINTS TO BE FULLY WELDED. WELDS TO BE 5 THICK C.F.W (CONTINUOUS FILLET WELDS) TO AS554.1
9. GATE AND ADJACENT POSTS TO BE POWDER COATED 'YELLOW'.

SUPERSEDED REVISION  
July 2019  
Not to be Published

ISSUE	AMENDMENT	DRAWN DATE	CHK'D DATE	APPR'D DATE
A	ORIGINAL ISSUE	DEC '14	DEC '14	DEC '14

DRAWING AUTHORISED FOR PUBLICATION			
Inga Condric 2015.06.04 14:37:10+10'00' pof ASSET ENGINEERING MANAGER STRATEGIC ASSET MANAGEMENT DESIGN APPROVED C.Wood SENIOR CO-ORDINATOR NATURAL ENVIRONMENT ASSET SERVICES/BRISBANE INFRASTRUCTURE			
DESIGN	CPO - P&D	DATE	DEC '14
DRAWN	CPO - P&D	DATE	DEC '14
CHECKED	BI - FSG - AS	DATE	DEC '14
DRAWING FILENAME	BSD-7057 (A) Vehicle access gate - Natural area - Medium duty.dwg		
ASSOCIATED PLANS			



<b>BRISBANE CITY COUNCIL STANDARD DRAWING</b>	
<b>VEHICLE ACCESS GATE NATURAL AREA MEDIUM DUTY</b>	SCALE AS SHOWN <b>BSD-7057</b> ORIGINAL SIZE A3 REVISION A