

STONEPITCHED RETAINING WALL VERTICAL FACE

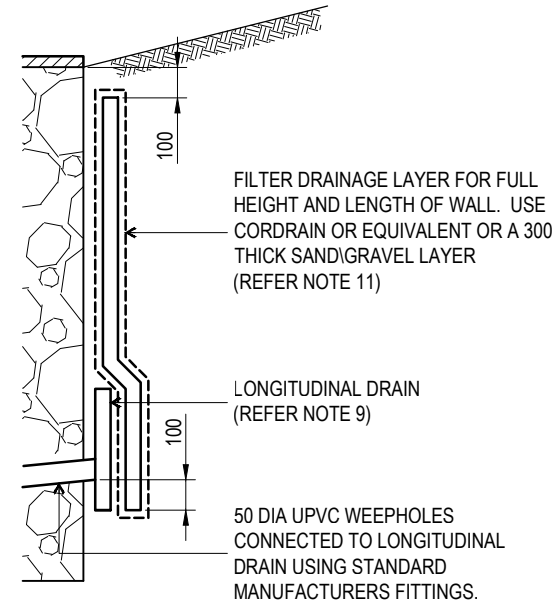

DRAINAGE DETAIL

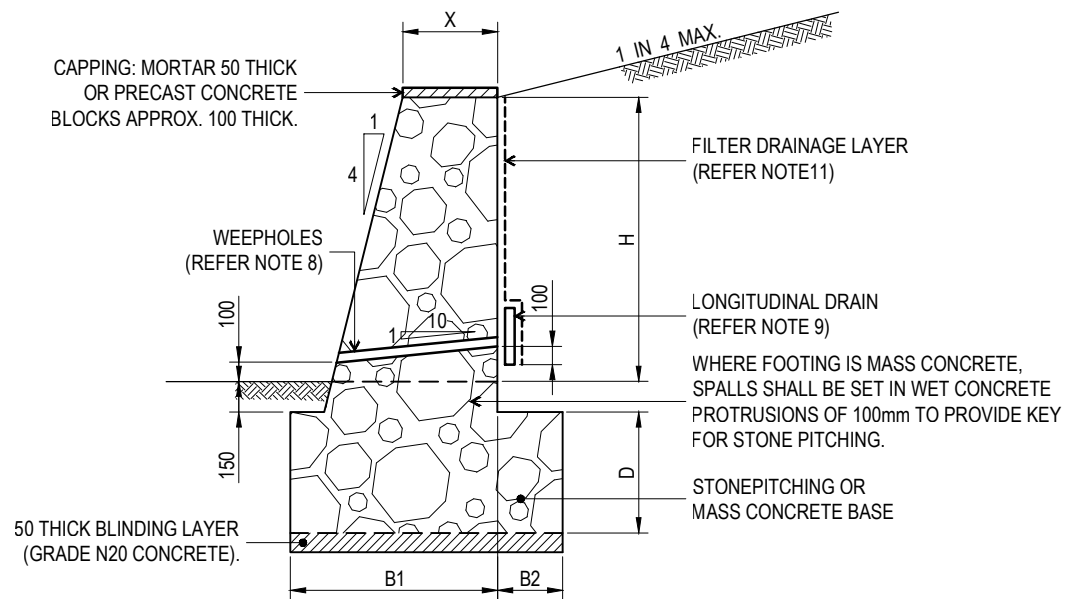

NOTE:
IF A FLATTER SLOPE TO BE ADOPTED FOR THE FRONT WALL FACE, INCREASE B1 TO SUIT. 4 IN 1 FACE SLOPE SHALL BE THE MINIMUM.

STONEPITCHED RETAINING WALL 4 IN 1 FACE SLOPE

WALL DIMENSIONS					
FOR BACKFILL SLOPES UP TO 1 IN 4 WITH 5 kPa SURCHARGE					
H	X	D	B1	B2	B3
0-400	400	400	700	0	700
401-750	400	400	800	250	850
751-1000	400	500	850	400	1100
1001-1250	450	500	1000	550	1250
1254-1500	500	500	1100	650	1500

NOTES:

- PROJECT ENGINEER (RPEQ) TO VERIFY LOCATIONS OF ALL SERVICES PRIOR TO COMMENCING OF WORK AND AVOID OVERSTRESSING SERVICES FROM RETAINING WALL.
- ALL WORKMANSHIP AND MATERIAL SHALL COMPLY WITH THE APPROPRIATE AUSTRALIAN STANDARDS THE ARE CURRENT AT THE TIME OF CONSTRUCTION.
- THE WALLS HAVE BEEN DESIGNED IN ACCORDANCE WITH AS4678 - 2002 FOR A DESIGN LIFE OF 50 YEARS AND ON THE ASSUMPTION THAT A MINIMUM ALLOWABLE BEARING CAPACITY OF 100 kPa, A MINIMUM EFFECTIVE FRICTION ANGLE OF 32° AND BULK DENSITY OF 19 kN/m³ ARE AVAILABLE ON SITE FOR FOUNDING MATERIAL.
NOTE THE FOLLOWING DESIGN LOAD LIMITATIONS:
 - THE DESIGN IS NOT FOR VEHICLE LOADINGS HENCE A VEHICLE LOAD ON THE UPHILL LEVEL SHALL BE NO CLOSER THAN A DISTANCE WHERE A 45 DEG LINE TAKEN FROM THE REAR BOTTOM OF THE BASE INTERSECTS THE SURFACE LEVEL BEHIND THE WALL.
 - THE DESIGN DOES NOT ACCOUNT FOR LOADING FROM OTHER WALLS BEHIND THE PROPOSED WALL HENCE THE PROPOSED NEW RETAINING WALL FOOTING SHALL BE SEPARATED FROM ANY EXISTING WALL FOOTINGS BY A CLEAR DISTANCE NOT LESS THEN THEIR BASE LEVEL DIFFERENCE.
- A GEOTECHNICAL ENGINEER (RPEQ) TO CERTIFY THAT THE ASSUMED GEOTECHNICAL PARAMETERS IN NOTE 3 CAN BE ACHIEVED ON SITE. IF THEY CANNOT BE ACHIEVED, A STRUCTURAL ENGINEER (RPEQ) TO BE CONSULTED TO REDESIGN THE FOOTINGS.
- THE CONTRACTOR'S GEOTECHNICAL ENGINEER (RPEQ) SHALL CERTIFY THAT:
 - THE COMBINED VERTICAL COMPACTION PRESSURES AND CONSTRUCTION SURCHARGE BEHIND THE WALL DO NOT EXCEED 5.0 kPa PRESSURE DURING CONSTRUCTION.
 - LATERAL COMPACTION INDUCED PRESSURES ON THE BACK OF THE WALL ARE RELIEVED BEFORE THE END OF CONSTRUCTION.
 - NO COMPACTION IS TO OCCUR WITHIN 300mm FROM THE BACK OF THE WALL.
- MORTAR TO BE 1 PART CEMENT TO 3 PARTS SAND (BY VOLUME). FACE JOINTS TO BE 25mm NOMINAL WIDTH.
- ROCKS TO BE SELECTED SPALLS SET IN CEMENT MORTAR BEDS IN HORIZONTAL LAYERS. UNLESS SPECIFIED OTHERWISE OPEN FACE STONEPITCHING TO BE USED WHERE THE MORTAR IS RECESSED 50 BEHIND THE STONE FACING. IF CLOSED FACE STONEPITCHING IS SPECIFIED, MORTAR TO BE FLUSH WITH THE STONE FACING. SELECT SPALLS TO AVOID SHARP EDGES.
- INSTALL WEEPHOLES IN ADDITION TO THE LONGITUDINAL DRAIN. WEEPHOLES TO BE 50 DIA UPVC AT 1000 TO 1400 CENTRES, POSITIONED AT APPROX. 100 CONSTANT HEIGHT ABOVE ULTIMATE GROUND LEVEL AND CONNECTED TO THE LONGITUDINAL DRAIN USING STANDARD MANUFACTURERS FITTINGS.
- LONGITUDINAL DRAIN SHALL BE 300x50 MEGAFLOW OR 100 DIA CORRUGATED PERFORATED POLYETHYLENE PIPE, ENCASED WITH BIDIM A24 OR EQUIVALENT. THE INVERT OF THE LONGITUDINAL DRAIN SHALL BE 100 BELOW THE INVERT OF THE WEEPHOLE INLET. PREFERABLY THE LONGITUDINAL DRAIN SHALL OUTLET TO THE KERB AND CHANNEL, STORMWATER PIPE OR GULLY AT A MINIMUM SLOPE OF 1 IN 200 AND AT 25m INTERVALS. WHERE SUCH AN OUTLET IS NOT ACHIEVABLE, THE INVERTS OF THE LONGITUDINAL DRAIN AND THE WEEPHOLE INLET SHALL BE ALIGNED TO ALLOW DIRECT DISCHARGE VIA THE WEEPHOLE.
- ALL CONNECTIONS, INCLUDING THE JOINING OF LENGTHS OF MEGAFLOW OR CORRUGATED PERFORATED POLYETHYLENE PIPE, SHALL BE MADE USING STANDARD MANUFACTURERS FITTINGS.
- FILTER DRAINAGE LAYER FOR FULL HEIGHT AND LENGTH OF WALL TO BE CORDRAIN OR EQUIVALENT WITH BIDIM A24 GEOTEXTILE OR EQUIVALENT ADHERED TO BOTH SIDES. ALTERNATIVELY, A 300 THICK, FREE DRAINING FILTER SAND/GRAVEL LAYER SEPARATED FROM INSITU MATERIAL WITH A LAYER OF BIDIM A24 GEOTEXTILE.
- BACKFILL SHALL BE FREE DRAINING, NON PLASTIC PREDOMINANTLY GRANULAR MATERIAL WITH MINIMUM EFFECTIVE FRICTION ANGLE OF 32° AND BULK DENSITY OF 19 kN/m³. DO NOT PLACE BACKFILL BEHIND THE WALL UNTIL AT LEAST 10 DAYS AFTER WALL CONSTRUCTION.
- ALL COUNCIL RETAINING WALLS TO BE CONSTRUCTED IN THE ROAD RESERVE WHERE POSSIBLE. PRIVATE WALLS INCLUDING FOOTING TO BE CONTAINED WHOLLY WITHIN PRIVATE PROPERTY.
- DIMENSIONS IN MILLIMETRES (U.N.O.).

THE PURPOSE OF THIS STANDARD DRAWING IS TO PROVIDE TYPICAL DETAILS THAT SUPPORT THE DESIRED OUTCOMES OF THE BRISBANE CITY PLAN 2014 AND ASSOCIATED PLANNING SCHEME POLICIES. THE FITNESS FOR PURPOSE OF THIS STANDARD DRAWING FOR A SPECIFIC PROJECT SHOULD BE ASSESSED AND ACCEPTED BY AN APPROPRIATELY QUALIFIED DESIGNER AND/OR REGISTERED PROFESSIONAL ENGINEER OF QUEENSLAND (RPEQ).



BRISBANE CITY COUNCIL STANDARD DRAWING

RETAINING WALL
STONEPITCHED

PUBLISH DATE	DEC 2023
SCALE	NOT TO SCALE
DRAWING NUMBER	BSD-2221
ORIGINAL SIZE	A3
REVISION	D