

# STANDARDS

DESIGNED IN ACCORDANCE WITH, AND FABRICATION TO MEET THE FOLLOWING STANDARDS:

- AS1428.4.1:2009, TACTILE GROUND SURFACE INDICATORS FOR THE ORIENTATION OF PEOPLE WITH VISION IMPAIRMENT.
- AS1627.4 METAL FINISHING – PREPARATION AND PRE-TREATMENT OF SURFACES – ABRASIVE BLAST CLEANING OF STEEL.
- AS2312:2002/AMDT 1:2004. GUIDE TO PROTECTION OF IRON AND STEEL AGAINST EXTERIOR ATMOSPHERIC CORROSION, 1994.
- GUIDE TO ENGINEERING PRACTICE, 'PEDESTRIANS', PART 13, AUSTRROADS.
- AUSTRALIAN ROAD RULES , 1999, WWW.NRTC.GOV.AU
- AS4506 –2005, METAL FINISHING– THERMOSET POWDER COATINGS.
- AS4680:2006, HOT DIP GALVANISING.
- AS 1742.10– 2009 MANUAL OF UNIFORM TRAFFIC CONTROL DEVICES: 'PEDESTRIAN CONTROL AND PROTECTION'

# NOTES

- WELDING TO BE ACCORDANCE TO AS1554.1 CAT GP WELDING, ALL SHARP EDGES & BURRS REMOVED.
- PART SHOULD BE SUPPLIED CLEAN AND FREE FROM MARKS, BURRS, SCUFFS, DISTORTION AND WARPAGE.
- ENSURE ANTI-SEIZE IS ON ALL NUTS AND BOLTS PRIOR TO ASSEMBLY.
- DRAWING TO AS1100 DRAWING STANDARDS.
- 316 S.S AND 316 S.S FASTENERS TO BE USED THROUGHOUT FOR COASTAL INSTALLATIONS OR ANY ENVIRONMENT WITH HIGH CORROSION.
- ALL TOLERANCES  $\pm 1.5\text{mm}$  UNLESS OTHERWISE SPECIFIED.

# MATERIAL

- MATERIAL: 316 STAINLESS STEEL
- COLOUR: NATURAL
- FINISH: GARNET BLASTED

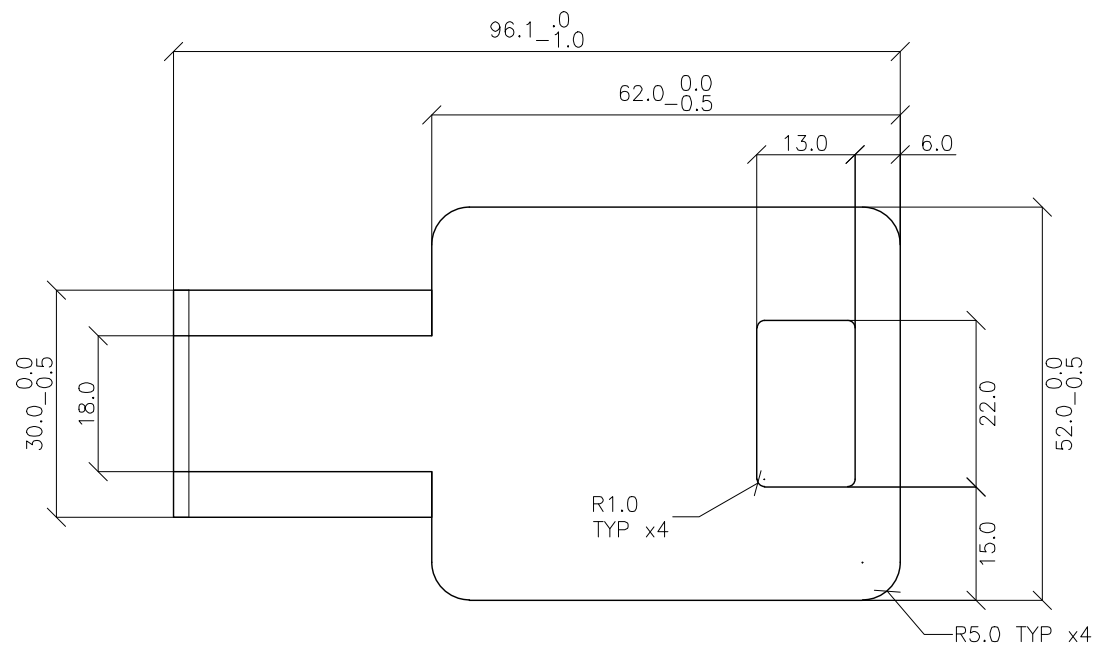

TOP VIEW

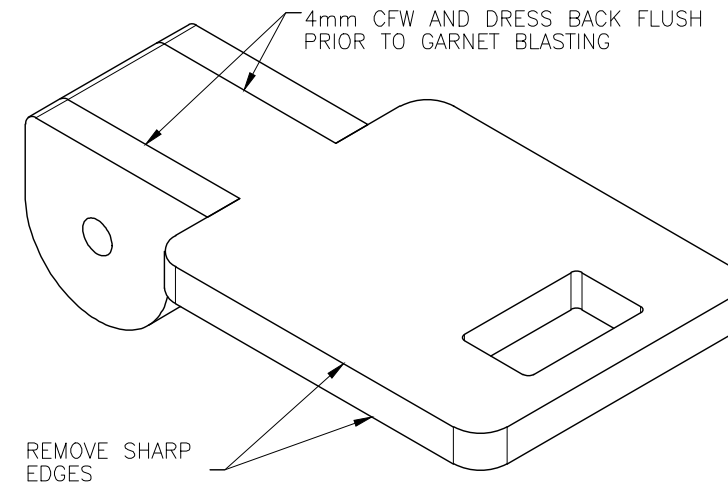

PICTORIAL VIEW

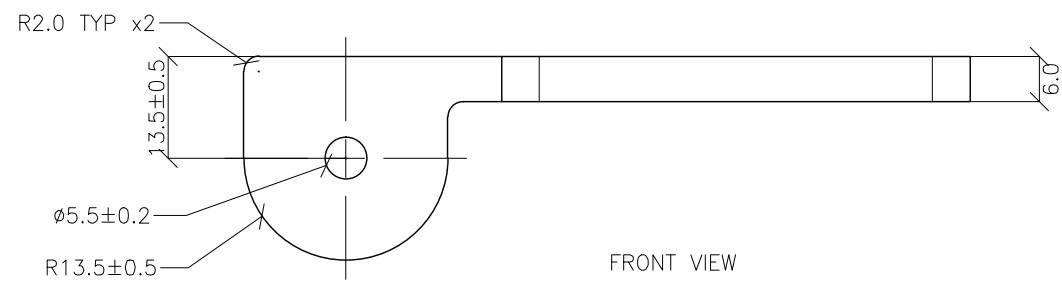

FRONT VIEW

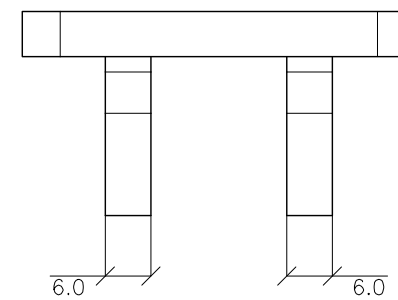

SIDE VIEW

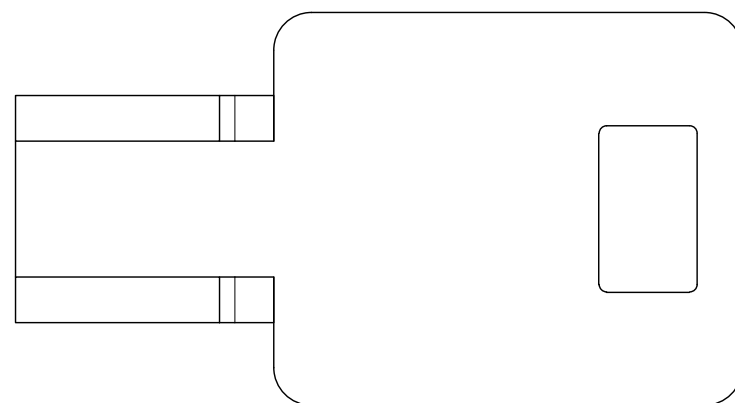

UNDERSIDE VIEW

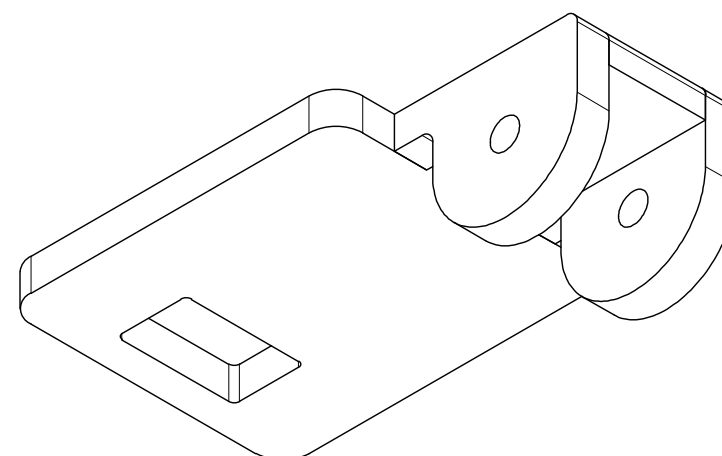

PICTORIAL VIEW

STRUCTURAL DESIGN REVIEWED AND CERTIFIED FOR ISSUE

NAME: B.C. PLANT RPEQ: 8807

SIGNATURE: ON ORIGINAL DATE: 28/6/12

ISSUE	AMENDMENT	DRAWN DATE	CHK'D DATE	APPR'D DATE
B	Drawing Title Amended	FEB '16	JUL '16	JUL '16
A	Drawing Converted from UMS Series April 2014	APR '14	APR '14	APR '14

DRAWING AUTHORISED FOR PUBLICATION  
INGA CONDRIK AUTHORISED 15/04/2014

ASSET ENGINEERING MANAGER  
STRATEGIC ASSET MANAGEMENT

DESIGN APPROVED

VICKI MARTIN SIGNATURE ON ORIGINAL

PRINCIPAL PLANNING OFFICER  
URBAN DESIGN

DESIGN	FORMZOO DESIGN	DATE	JUN '12
DRAWN	AB	DATE	JUN '12
CHECKED	VM	DATE	APR '13
DRAWING FILENAME	BSD-7096-4.dwg		
ASSOCIATED PLANS	SUPERSEDES UMS-567-7		



## BRISBANE CITY COUNCIL STANDARD DRAWING

STREETSCAPE  
REMOVABLE BOLLARD – COVER  
SHEET 4 OF 6

SCALE	
NOT TO SCALE	
DWG No. <b>BSD-7096</b>	
ORIGINAL SIZE	REVISION
A3	B