

PLAN

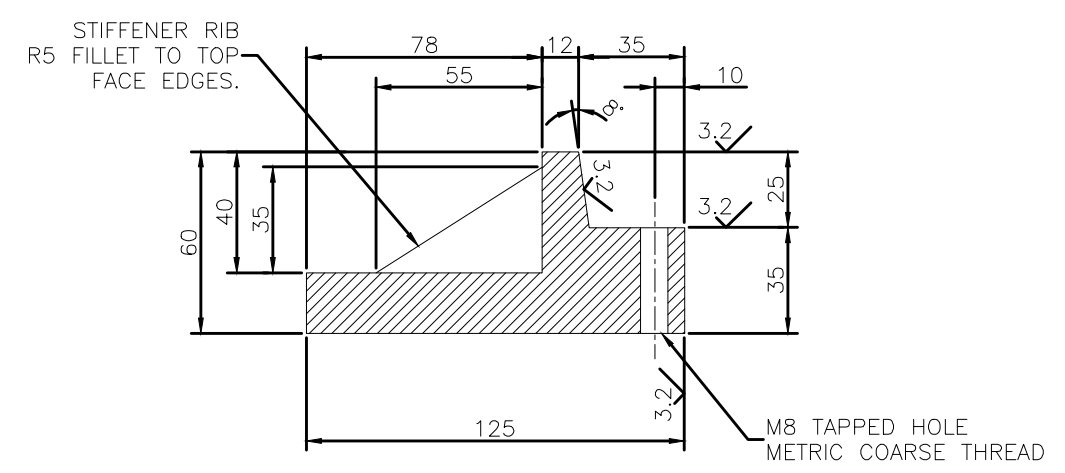

DETAIL 1

SPECIAL NOTE – ROADWAY USE
 COVERS, FRAMES AND 35mm RISER RINGS (MIN.)
 TO BE SUPPLIED ASSEMBLED.
 (RISER MUST BE USED WITH FRAME WHEN USED
 WITH ROADWAY MANHOLE COVER)

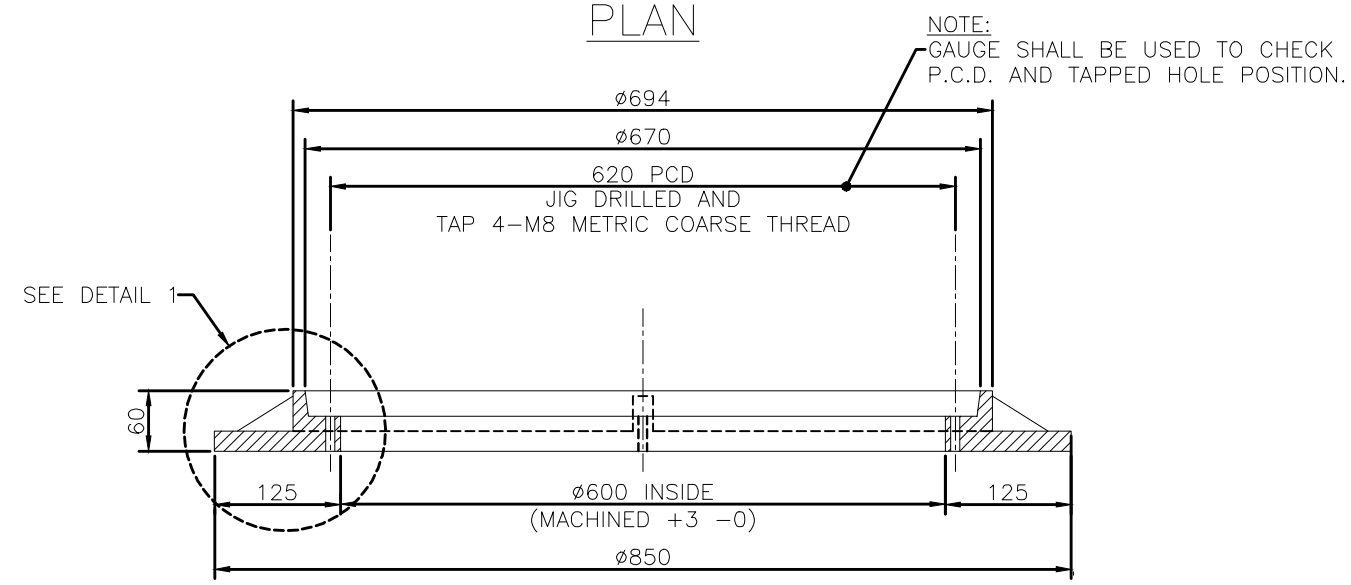

SECTION A-A
 SCALE NTS

NOTES:

- ALL EDGES TO BE SQUARE.
- CASTING TO BE FREE OF BURRS AND PITS.
- MATERIAL**
 GREY CAST IRON (AS 1830)
 TENSILE STRENGTH: T220
 HARDNESS: 145–185 (HB)
 DESIGN LOAD: 210kN (AS 3996)
 MASS: 59.5Kg
- TOLERANCES**
 CAST SIZE: ±1.00mm
 ANGLE PROFILE: ±0.25°
 MACHINED SIZE: ±0.125mm
 OVERALL DIAMETER OF COVER: +0mm–0.25mm
 DRY FILM THICKNESS (DFT) OF COATING: 50µm
- MACHINE SURFACE SYMBOL: 3.2/
- ALL MACHINED SURFACES SHALL HAVE A COATING APPROVED AS FIT FOR THE PURPOSE OF PROVIDING A RUST PROOF, NON-STICK AND GAS/WATER PROOF JOINT. (HAVTEC-HS1 OR SIMILAR)
- DIMENSIONS IN MILLIMETRES (U.N.O.).

B	Drawing Title Amended	FEB '16	JUL '16	JUL '16
A	Drawing Converted from UMS Series April 2014	APR '14	APR '14	APR '14
ISSUE	AMENDMENT	DRAWN DATE	CHK'D DATE	APPR'D DATE

DRAWING AUTHORISED FOR PUBLICATION B.BALL SIGNATURE ON ORIGINAL DATED 29/06/01			
MANAGER ASSET SUPPORT - R.P.E.Q: 3852			
DESIGN APPROVED B.HANSEN SIGNATURE ON ORIGINAL DATED 27/06/01			
PRINCIPAL ASSET OFFICER ROADS AND DRAINAGE			
DESIGN	STD DWG GROUP	DATE	APR '01
DRAWN	CITY DESIGN	DATE	APR '01
CHECKED	M.STEER	DATE	MAY '01
DRAWING FILENAME	BSD-8031 (B) Maintenance hole frame (roadway and non-roadway) 1050 to 1500 diameter.dwg		
ASSOCIATED PLANS	SUPERSEDES UMS-325		

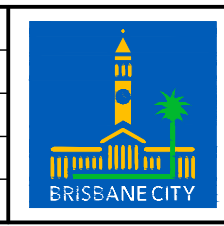

BRISBANE CITY COUNCIL STANDARD DRAWING

MAINTENANCE HOLE FRAME (ROADWAY & NON-ROADWAY) 1050 TO 1500 DIAMETER

SCALE: NOT TO SCALE

DWG No: **BSD-8031**

ORIGINAL SIZE: A3 REVISION: B