

LED LUMINAIRE (INCORPORATING A 7 PIN NEMA RECEPTACLE AND NEMA PE CELL)
 MAXIMUM WEIGHT: 8.4kg
 MAXIMUM WIND CATCHING AREA: 0.13m²
 MAXIMUM HEIGHT: 275mm

TOTAL MAXIMUM HEIGHT OF PEDESTRIAN LIGHT POLE AND LUMINAIRE TO NOT EXCEED 5275mm.

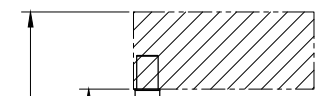

SEAL EXTERNAL BASE OF POLES WITH A NON-SHRINK GROUT UNDER BASE WITH MORTAR MIX OR SIMILAR SUITABLE MATERIAL TO PREVENT INGRESS OF VERMIN. ENSURE THE GROUT IS FLUSH WITH THE UNDERSIDE OF THE BASE PLATE AND TAPERED AWAY FROM THE POLE AT APPROXIMATELY 45°. A MINIMUM 12mm WEEP HOLE IS RECOMMENDED TO ALLOW FOR DRAINAGE OF CONDENSATION FROM INSIDE THE POLE.

REFER TO BSD-5202, 5206, 5207 AND 5210 FOR PAVEMENT DETAILS. REFER TO PROJECT DRAWINGS FOR FINISHES

5 N16 UBARS TOP AND BOTTOM EACH WAY.

CONCRETE PEDESTAL AS REQUIRED.

KERB AND CHANNEL

DAMP PROOF MEMBRANE.

GEOTECHNICAL ENGINEER TO CONFIRM THAT GROUND HAS MINIMUM 100kPa ALLOWABLE BEARING CAPACITY.

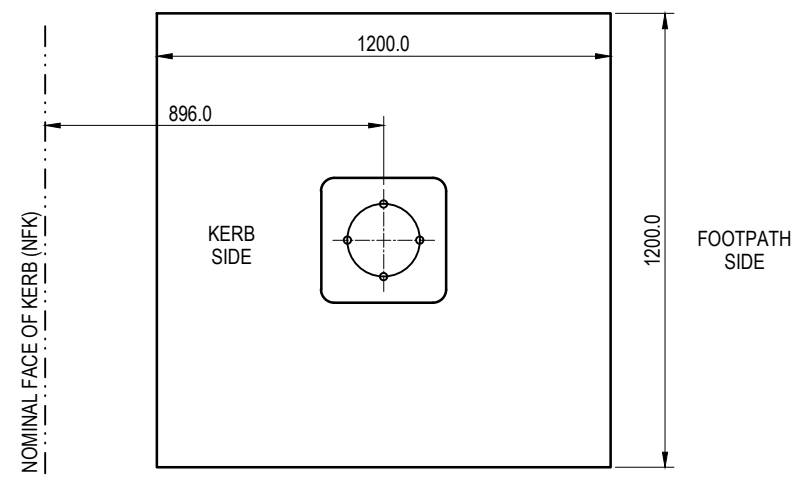

RAG BOLT, PEDESTAL AND FOOTING
 TOP VIEW
 SCALE 1:20

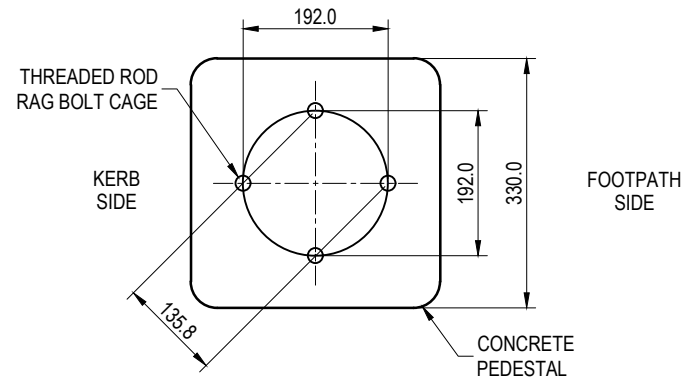

RAG BOLT AND PEDESTAL
 TOP VIEW
 NOT TO SCALE

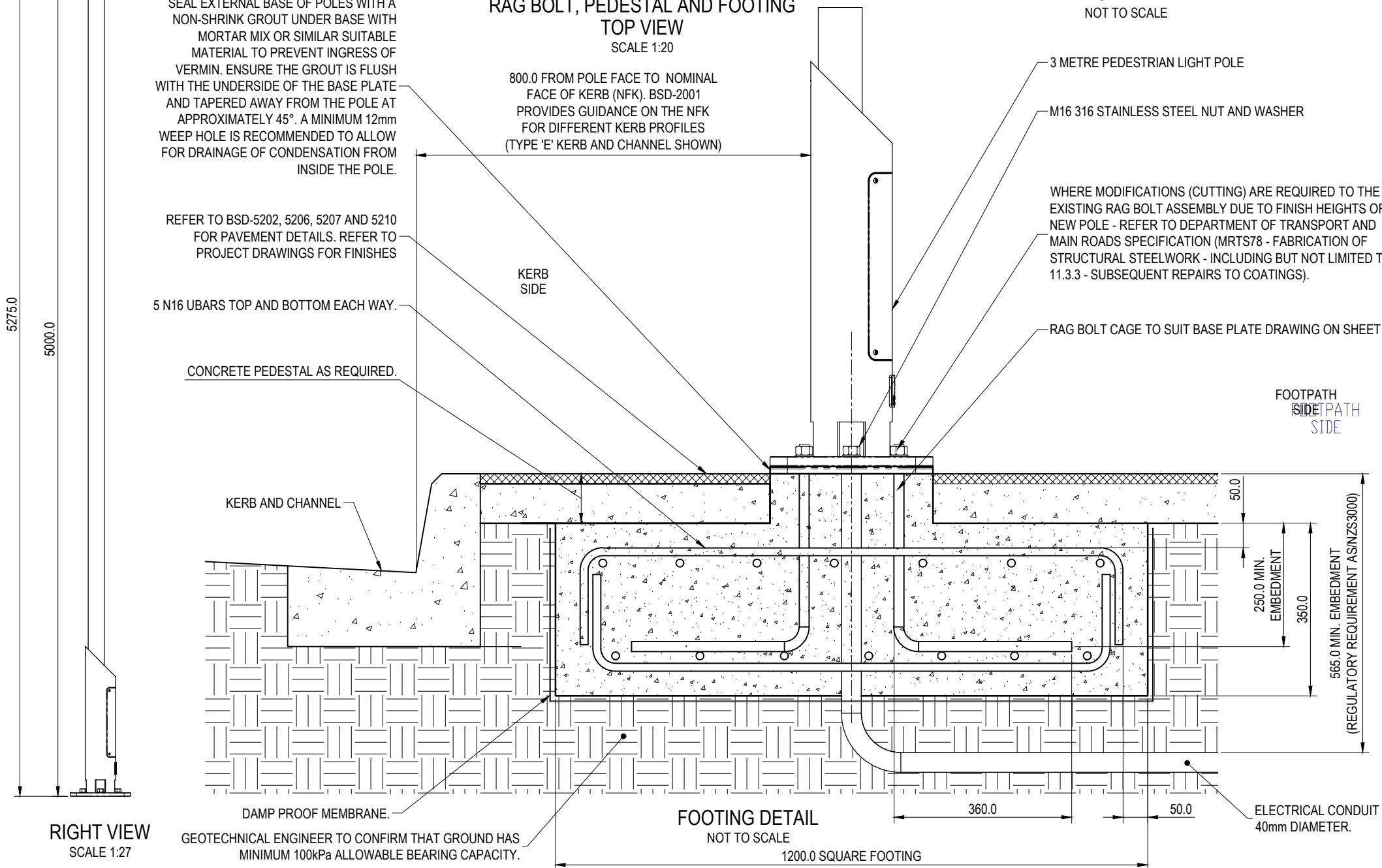

RIGHT VIEW
 SCALE 1:27

FOOTING DETAIL
 NOT TO SCALE

THE FITNESS FOR PURPOSE OF THIS STANDARD DRAWING FOR A SPECIFIC PROJECT SHALL BE ASSESSED AND ACCEPTED BY A SUITABLY QUALIFIED REGISTERED PROFESSIONAL ENGINEER OF QUEENSLAND (RPEQ).



BRISBANE CITY COUNCIL STANDARD DRAWING

5 METRE PEDESTRIAN LIGHT POLE
 INSTALLATION ON NEW FOOTING
 SHEET 7 OF 7

PUBLISH DATE		March 2021
SCALE		1:10
DRAWING NUMBER		BSD-11005
ORIGINAL SIZE	REVISION	
A3	A	

STANDARDS

DESIGNED IN ACCORDANCE WITH, FABRICATED AND INSTALLED TO MEET THE FOLLOWING STANDARDS:

- AS1428.4.1 - TACTILE GROUND SURFACE INDICATORS FOR THE ORIENTATION OF PEOPLE WITH VISION IMPAIRMENT.
- AUSTROADS GUIDE TO ROAD DESIGN, PART 6B: ROADSIDE ENVIRONMENT.
- AS1158.3.1 - ROAD LIGHTING, PART 3.1: PEDESTRIAN AREA (CATEGORY P) LIGHTING - PERFORMANCE AND INSTALLATION DESIGN REQUIREMENTS.
- AS1627.4 - METAL FINISHING - PREPARATION AND PRE-TREATMENT OF SURFACES - ABRASIVE BLAST CLEANING OF STEEL.
- AS2312/AMDT 1 - GUIDE TO PROTECTION OF IRON AND STEEL AGAINST EXTERIOR ATMOSPHERIC CORROSION.
- AS4680 - HOT DIP GALVANISING.
- AS4506 - METAL FINISHING-THERMOSET POWDER COATINGS.
- AS/NZS3000 - ELECTRICAL INSTALLATIONS

NOTES:

PART SHOULD BE SUPPLIED CLEAN AND FREE FROM MARKS, BURRS, SCUFFS, DISTORTION AND WARPAGE.

- ALL TOLERANCES ± 1.5 mm UNLESS OTHERWISE SPECIFIED.
- DRAWING TO AS1100 DRAWING STANDARDS.
- WELDING TO BE IN ACCORDANCE WITH AS1554.1 CAT GP WELDING, ALL SHARP EDGES & BURRS REMOVED.
- POWDER COATING TO BE IN ACCORDANCE TO AS4506 EXTERNAL EXPOSURE STANDARD WITH PRE-TREATMENT SAND BLAST, ZINC PHOSPHATE, ETC.
- ENSURE ANTI-SEIZE IS ON ALL NUTS AND BOLTS PRIOR TO ASSEMBLY.
- 316 S.S. AND 316 S.S. FASTENERS TO BE USED THROUGHOUT FOR COASTAL INSTALLATIONS OR ANY ENVIRONMENT WITH HIGH CORROSION.
- LIGHTING DESIGN IS TO BE CERTIFIED BY AN ELECTRICAL RPEQ OR MIES AND ELECTRICAL DESIGN IS TO BE CERTIFIED BY AN ELECTRICAL RPEQ.
- THE CONTRACTOR IS TO ENSURE THAT ALL SERVICE PROVIDER APPROVALS ARE IN PLACE PRIOR TO THE COMMENCEMENT OF WORKS.
- ALL ELECTRICAL WORK IS TO BE UNDERTAKEN BY A QUEENSLAND LICENSED ELECTRICAL CONTRACTOR TO AUSTRALIAN STANDARDS AND COUNCIL REQUIREMENTS.
- CONCRETE TO BE N25 AND COVER TO ALL REINFORCING STEEL TO BE 50mm.
- ANY DESIGN AMENDMENTS THAT DIFFER FROM THESE DRAWINGS, INCLUDING LUMINAIRE OR OTHER POLE LOADING REQUIREMENTS WILL REQUIRE CERTIFICATION FROM A SUITABLY QUALIFIED ENGINEER.

MATERIALS

- MATERIAL: SEE COMPONENT DRAWING
- COLOUR: SEE COMPONENT DRAWING
- FINISH: SEE COMPONENT DRAWING

DESIGN NOTES:

- STRUCTURAL ELEMENTS DESIGNED FOR THE FOLLOWING WIND CONDITIONS:
 - LOCATION AND WIND: CITY OF BRISBANE. REGION B, ULTIMATE VR: 57 m/s, SERVICEABILITY VR: 39m/s
 - COMPONENTS CERTIFIED: MAIN STRUCTURE
- SHOULD CONDITIONS VARY FROM THOSE DESCRIBED, SEEK PROFESSIONAL ENGINEERING ADVICE.
- LED LUMINAIRE, ACCESS HATCH, LOGO BADGE AND MAIN BODY ASSEMBLY AS PER MANUFACTURER'S SPECIFICATIONS.
- ORIGINAL CERTIFICATION SHALL NOT BE CONSTRUED AS RELIEVING ANY OTHER PARTY OR THEIR RESPONSIBILITIES, LIABILITIES OR CONTRACTUAL OBLIGATIONS.