

PICTORIAL VIEW

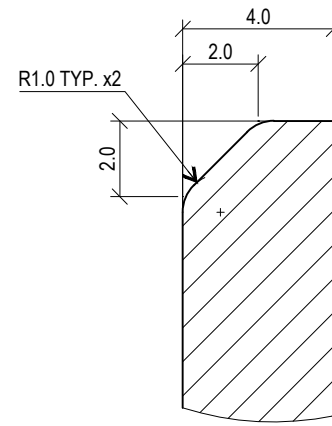

DETAIL F
SCALE 5 : 1

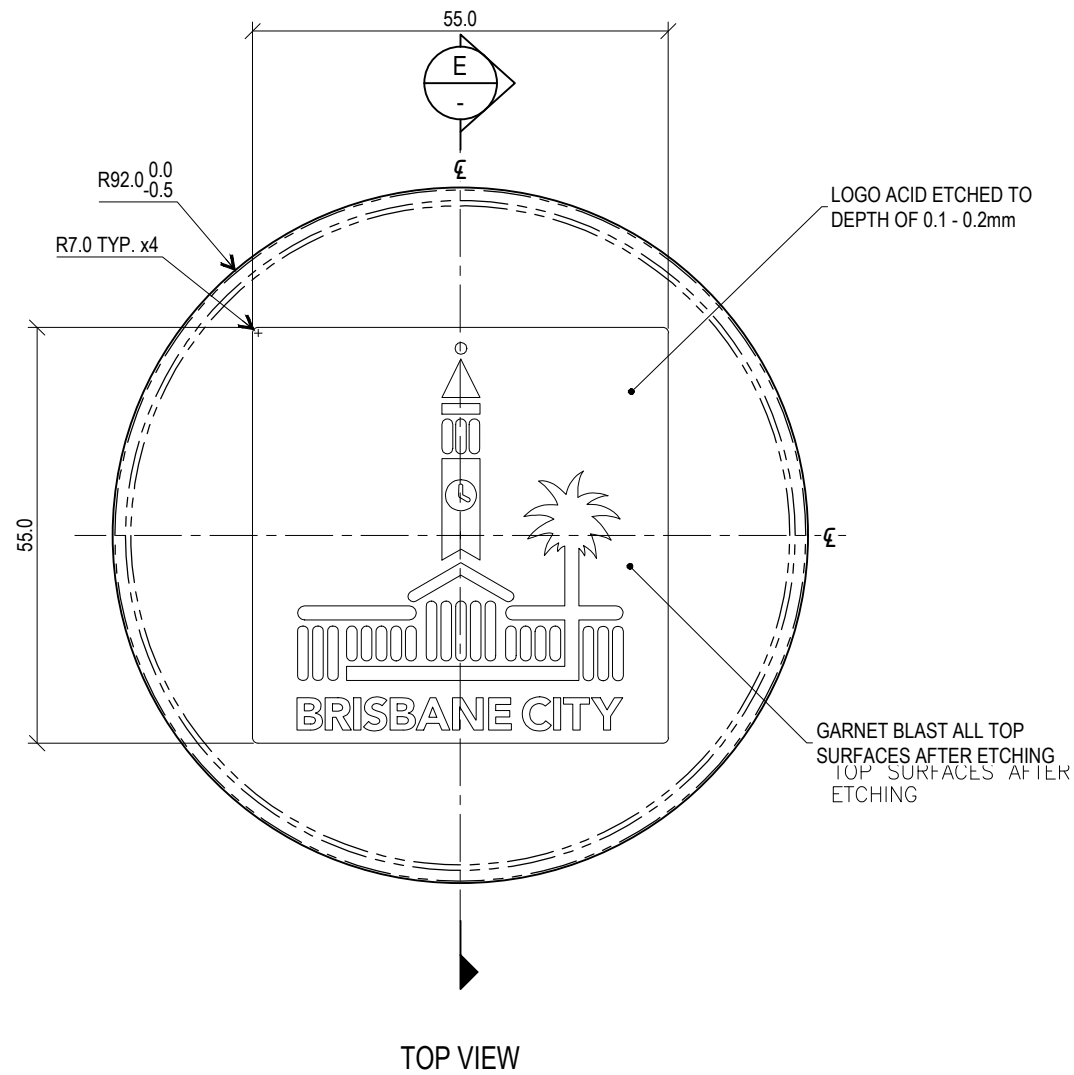
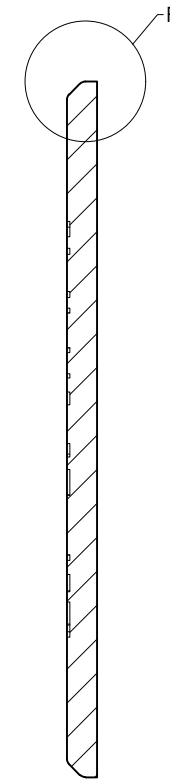

STANDARDS

DESIGNED IN ACCORDANCE WITH, AND FABRICATION TO MEET THE FOLLOWING STANDARDS:

- AS1627.4: METAL FINISHING - PREPARATION AND PRE-TREATMENT OF SURFACES - ABRASIVE BLAST CLEANING OF STEEL.
- AS2312:2002/AMDT 1:2004: GUIDE TO PROTECTION OF IRON AND STEEL AGAINST EXTERIOR ATMOSPHERIC CORROSION, 1994.

NOTES

- PART SHOULD BE SUPPLIED CLEAN AND FREE FROM MARKS, BURRS, SCUFFS, DISTORTION AND WARPAGE.
- DRAWING TO AS1100 DRAWING STANDARDS.

MATERIAL

- MATERIAL: 316 STAINLESS STEEL.
- COLOUR: NATURAL.
- FINISH: GARNET BLASTED.

THE FITNESS FOR PURPOSE OF THIS STANDARD DRAWING FOR A SPECIFIC PROJECT SHALL BE ASSESSED AND ACCEPTED BY A SUITABLY QUALIFIED REGISTERED PROFESSIONAL ENGINEER OF QUEENSLAND (RPEQ).

	BRISBANE CITY COUNCIL STANDARD DRAWING		PUBLISH DATE	MArch 2021
	URBAN STOOL CAP SHEET 4 OF 5		SCALE	NOT TO SCALE
			DRAWING NUMBER	BSD-7204
	ORIGINAL SIZE	A3	REVISION	E