

STANDARDS

DESIGNED IN ACCORDANCE WITH, AND FABRICATION TO MEET THE FOLLOWING STANDARDS:

- AS1627.4 METAL FINISHING -PREPARATION AND PRE-TREATMENT OF SURFACES - ABRASIVE BLAST CLEANING OF STEEL.
- AS2312:2002/AMDT 1:2004, GUIDE TO PROTECTION OF IRON AND STEEL AGAINST EXTERIOR ATMOSPHERIC CORROSION, 1994.

NOTES

- WELDING TO BE ACCORDANCE TO AS1554.1 CAT GP WELDING, ALL SHARP EDGES & BURRS REMOVED.
- PART SHOULD BE SUPPLIED CLEAN AND FREE FROM MARKS, BURRS, SCUFFS, DISTORTION AND WARPAGE.
- ENSURE ANTI-SEIZE IS ON ALL NUTS AND BOLTS PRIOR TO ASSEMBLY.
- DRAWING TO AS1100 DRAWING STANDARDS.

MATERIAL

- MATERIAL: SEE COMPONENT DRAWING
- COLOUR: SEE COMPONENT DRAWING
- FINISH: SEE COMPONENT DRAWING

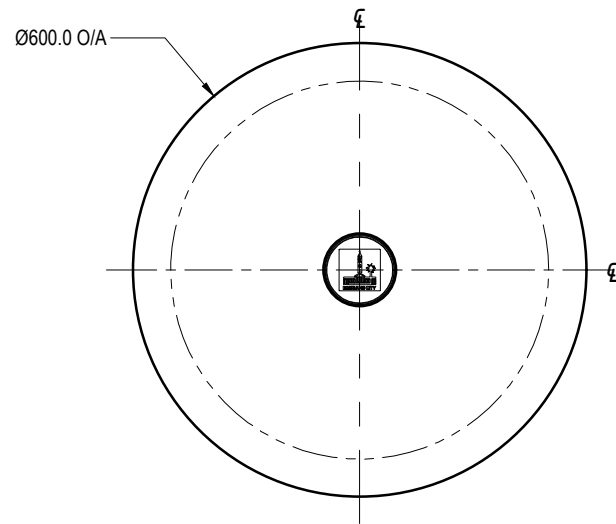

TOP VIEW

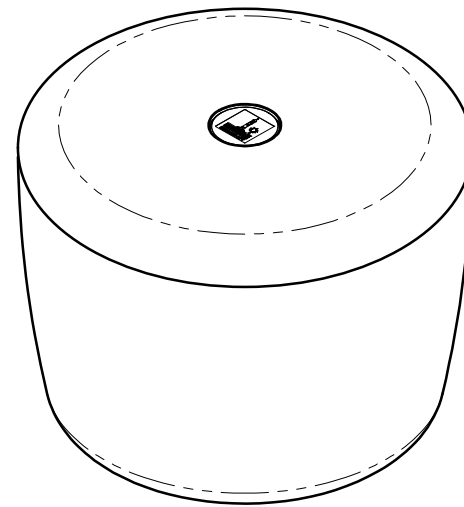

PICTORIAL VIEW

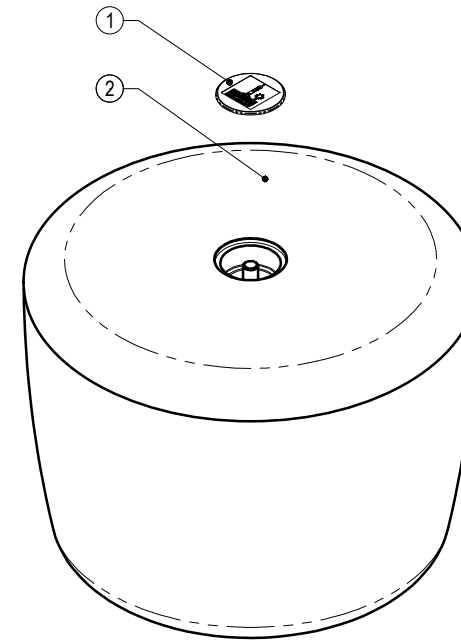

EXPLODED VIEW

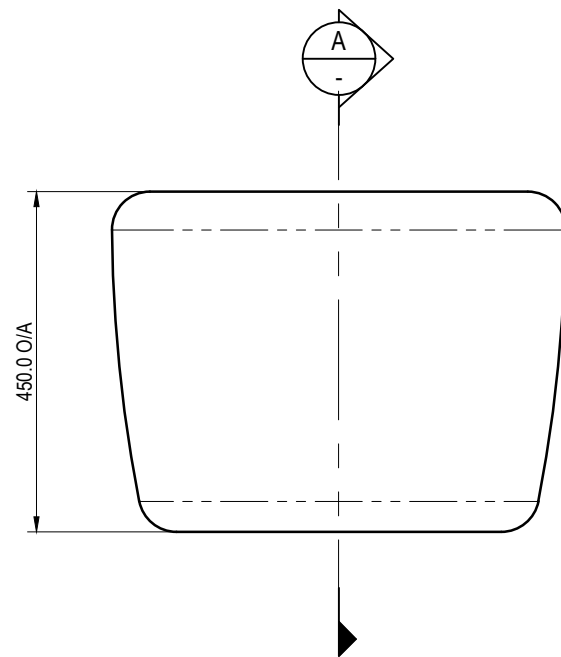

FRONT VIEW

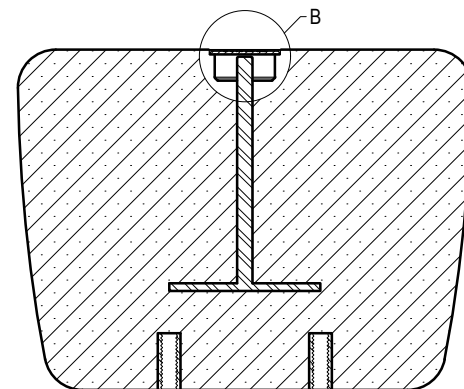

SECTION A-A

STAINLESS STEEL CAP BOTTOMS OUT ON SHOULDER OF CAST CONCRETE STOOL
 AFTER INSTALLATION ON SITE, LOGO PLATE TO BE SECURED WITH ADHESIVE - SIKAFLEX 11FC OR EQUIVALENT FOR METAL TO CONCRETE BOND

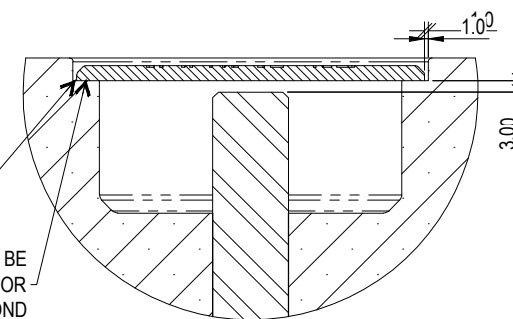

DETAIL B
 CAP ASSEMBLY DETAIL
 SCALE 1 : 2

ITEM NO.	DESCRIPTION	QTY.
1	Urban Stool Cap	1
2	Urban Stool	1

THE FITNESS FOR PURPOSE OF THIS STANDARD DRAWING FOR A SPECIFIC PROJECT SHALL BE ASSESSED AND ACCEPTED BY A SUITABLY QUALIFIED REGISTERED PROFESSIONAL ENGINEER OF QUEENSLAND (RPEQ).



BRISBANE CITY COUNCIL STANDARD DRAWING

URBAN STOOL
 ASSEMBLY
 SHEET 2 OF 5

PUBLISH DATE		March 2021
SCALE		NOT TO SCALE
DRAWING NUMBER		BSD-7204
ORIGINAL SIZE	REVISION	
A3	E	