

PLAN

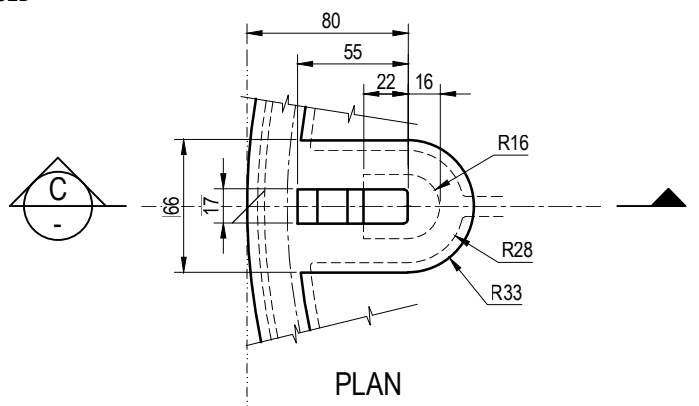

PLAN

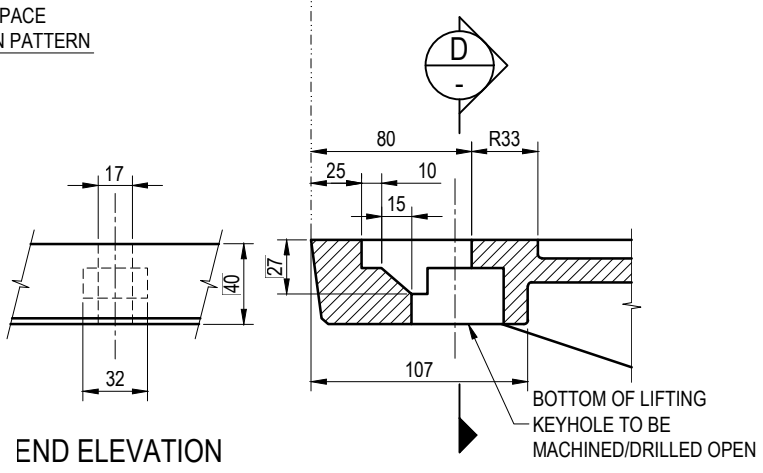

END ELEVATION

SECTION C
SCALE: N.T.S.
LIFTING KEYHOLE DETAIL

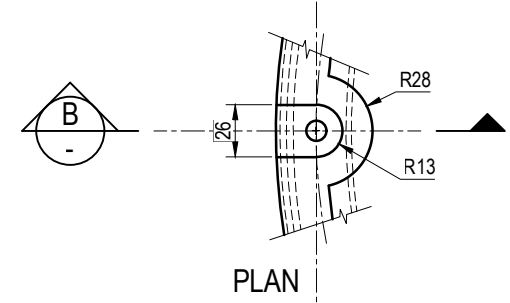

PLAN

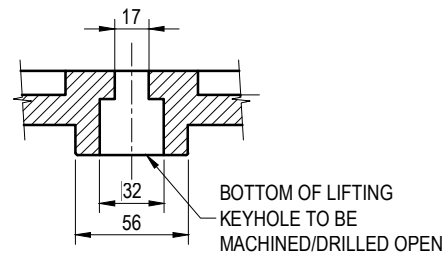

SECTION D
SCALE: N.T.S.

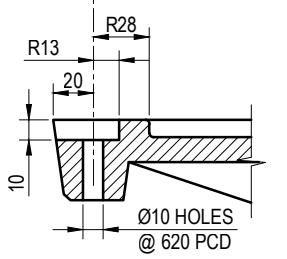

SECTION B
SCALE: N.T.S.

BOLTING BOSS DETAIL

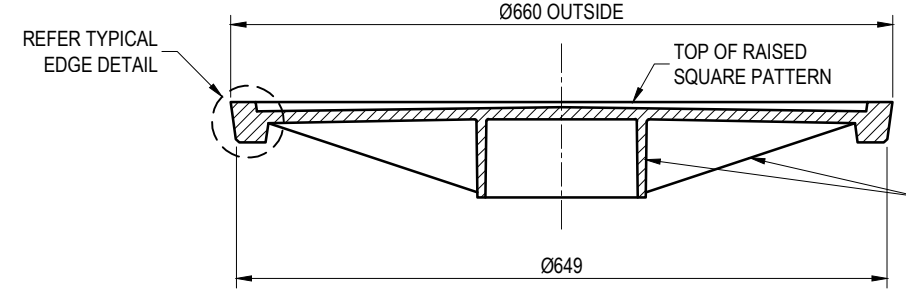

TYPICAL SECTION A
SCALE: N.T.S.

STRUCTURAL RIBS SHOWN INDICATIVE ONLY - WILL VARY DEPENDING ON PRODUCT USED.

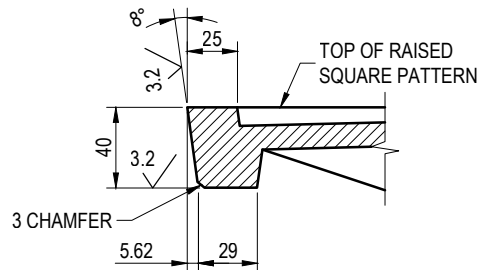

TYPICAL EDGE DETAIL

NOTES:

- PROPRIETARY PRODUCTS TO BE FULLY COMPATIBLE WITH BRISBANE CITY COUNCIL STANDARD MAINTENANCE HOLE FRAME (BSD-8031) AND RISER (BSD-8032). PROPRIETARY COVERS MUST BE ABLE TO BE DIRECTLY SUBSTITUTED FOR EXISTING COVERS.
- MATERIAL: TYPICALLY CAST DUCTILE IRON. OTHER MATERIALS WILL BE CONSIDERED UPON REQUEST.
- ALL EDGES TO BE SQUARE.
- CASTING TO BE FREE OF BURRS AND PITS.
- DESIGN LOAD OF COVER = CLASS 'D' TO AS3996.
- MAXIMUM MASS OF COVER = 50Kg
- TOLERANCES**
CAST SIZE: ±1.00mm
ANGLE PROFILE: ±0.25°
MACHINED SIZE: ±0.125mm
OVERALL DIAMETER OF COVER: +0mm-0.25mm
DRY FILM THICKNESS (DFT) OF COATING: 50µm
- MACHINE SURFACE SYMBOL $\sqrt{3.2}$
- ALL MACHINED SURFACES SHALL HAVE A COATING APPROVED AS FIT FOR THE PURPOSE OF PROVIDING A RUST PROOF, NON-STICK AND GAS/WATER PROOF JOINT. (HAVTEC-HS1 OR SIMILAR)
- COVERS TO BE BOLTED DOWN IF DIRECTED BY DESIGNER. MIN. TWO EXTRA LENGTH BOLTS MUST BE USED TO SECURE COVER AND RISER TO FRAME. REFER TO BSD-8032 FOR RISER DETAIL AND BOLT LENGTHS.
- COVER TO BE PERMANENTLY MARKED AS PER AS3996. MANUFACTURER NAME/REGISTERED TRADEMARK, STANDARD NUMBER AND LOAD CLASS TO BE DISPLAYED ON COVER SURFACE AS SHOWN. OTHER MARKINGS MAY BE MARKED ON THE UNDERSIDE OF THE COVER.
- DIMENSIONS IN MILLIMETRES (U.N.O.).

SPECIAL NOTE - ROADWAY USE
COVERS, FRAMES AND 35mm RISER RINGS (MIN.) TO BE SUPPLIED ASSEMBLED.
(RISER MUST BE USED WITH FRAME WHEN USED WITH ROADWAY MANHOLE COVER)

THE FITNESS FOR PURPOSE OF THIS STANDARD DRAWING FOR A SPECIFIC PROJECT SHALL BE ASSESSED AND ACCEPTED BY A SUITABLY QUALIFIED REGISTERED PROFESSIONAL ENGINEER OF QUEENSLAND (RPEQ).

	BRISBANE CITY COUNCIL STANDARD DRAWING		PUBLISH DATE March 2021
	MAINTENANCE HOLE COVER (ROADWAY)		SCALE NOT TO SCALE
	1050 TO 1500 DIAMETER		DRAWING NUMBER BSD-8033
	ORIGINAL SIZE A3	REVISION C	