

**DETAIL 1**  
SCALE: N.T.S.

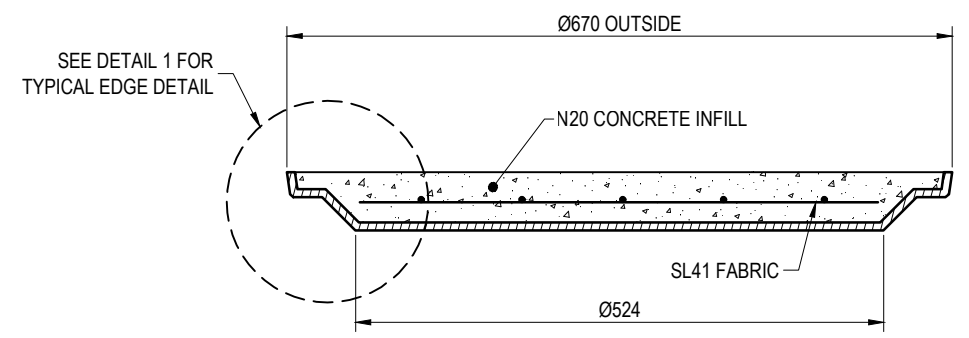

**SECTION A**  
SCALE: N.T.S.

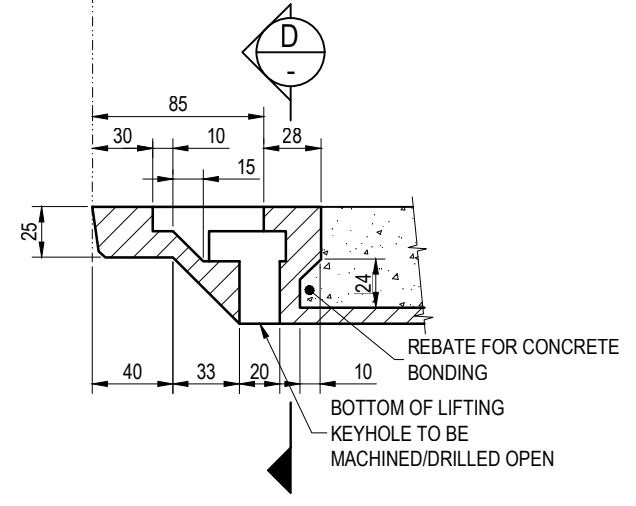
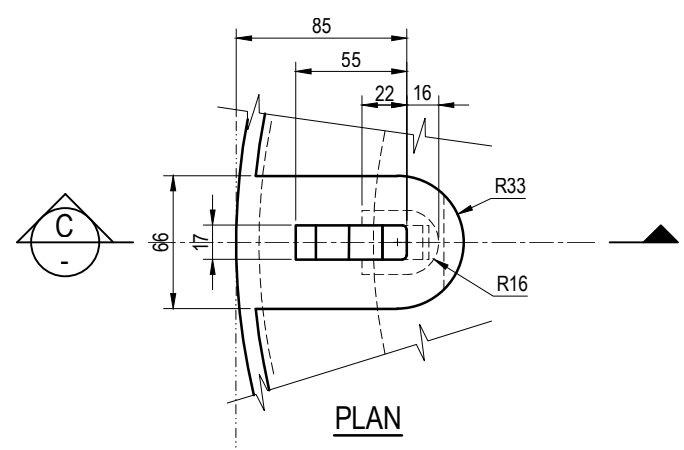

**SECTION C**  
SCALE: N.T.S.

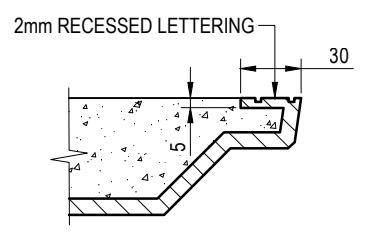

**SECTION B**  
SCALE: N.T.S.

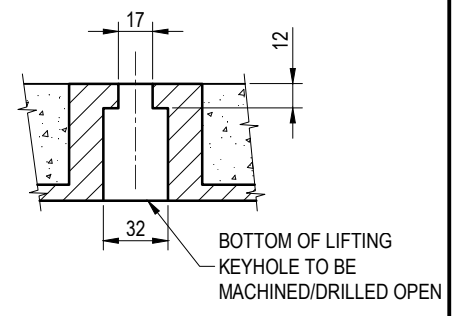

**SECTION D**  
SCALE: N.T.S.

**LIFTING KEYHOLE DETAILS**

**NOTES:**

- PROPRIETARY PRODUCTS TO BE FULLY COMPATIBLE WITH BRISBANE CITY COUNCIL STANDARD MAINTENANCE HOLE FRAME (BSD-8031). PROPRIETARY COVERS MUST BE ABLE TO BE DIRECTLY SUBSTITUTED FOR EXISTING COVERS.
- MATERIAL: TYPICALLY CAST DUCTILE IRON. OTHER MATERIALS WILL BE CONSIDERED UPON REQUEST.
- ALL EDGES TO BE SQUARE.
- CASTING TO BE FREE OF BURRS AND PITS.
- DESIGN LOAD OF COVER = CLASS 'B' TO AS3996.
- MAXIMUM MASS OF COVER = 60kg (INCLUDING CONCRETE INFILL).
- TOLERANCES  
CAST SIZE: ±1.00mm  
ANGLE PROFILE: ±0.25°  
MACHINED SIZE: ±0.125mm  
OVERALL DIAMETER OF COVER: +0mm-0.25mm  
DRY FILM THICKNESS (DFT) OF COATING: 50µm  
MACHINE SURFACE SYMBOL  $\sqrt{3.2}$
- ALL MACHINED SURFACES SHALL HAVE A COATING APPROVED AS FIT FOR THE PURPOSE OF PROVIDING A RUST PROOF, NON-STICK AND GAS/WATER PROOF JOINT. (HAVTEC-HS1 OR SIMILAR)
- COVER TO BE PERMANENTLY MARKED AS PER AS3996. MANUFACTURER NAME/REGISTERED TRADEMARK, 'B.C.C.' INITIALS, STANDARD NUMBER, LOAD CLASS AND MASS TO BE DISPLAYED ON COVER SURFACE AS SHOWN. OTHER MARKINGS MAY BE MARKED ON THE UNDERSIDE OF THE COVER.
- DIMENSIONS IN MILLIMETRES (U.N.O.).

**SPECIAL NOTE - NON-ROADWAY USE**  
THIS DRAWING IS FOR USE IN NON-ROADWAY APPLICATION SUBJECT TO PEDESTRIAN LOADINGS ONLY.

THE FITNESS FOR PURPOSE OF THIS STANDARD DRAWING FOR A SPECIFIC PROJECT SHALL BE ASSESSED AND ACCEPTED BY A SUITABLY QUALIFIED REGISTERED PROFESSIONAL ENGINEER OF QUEENSLAND (RPEQ).

	BRISBANE CITY COUNCIL STANDARD DRAWING		PUBLISH DATE March 2021	
	MAINTENANCE HOLE COVER CONCRETE INFILL (PEDESTRIAN TRAFFIC) 1050 TO 1500 DIAMETER		SCALE NOT TO SCALE	
			DRAWING NUMBER BSD-8035	
			ORIGINAL SIZE A3	REVISION C