

PLAN - TYPICAL INLET ON GRADE

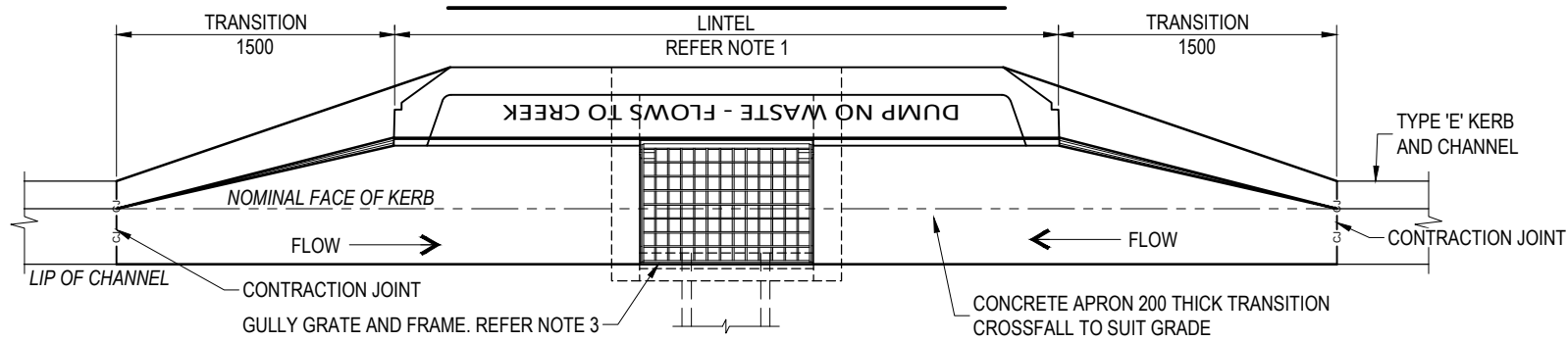

PLAN - TYPICAL INLET IN SAG

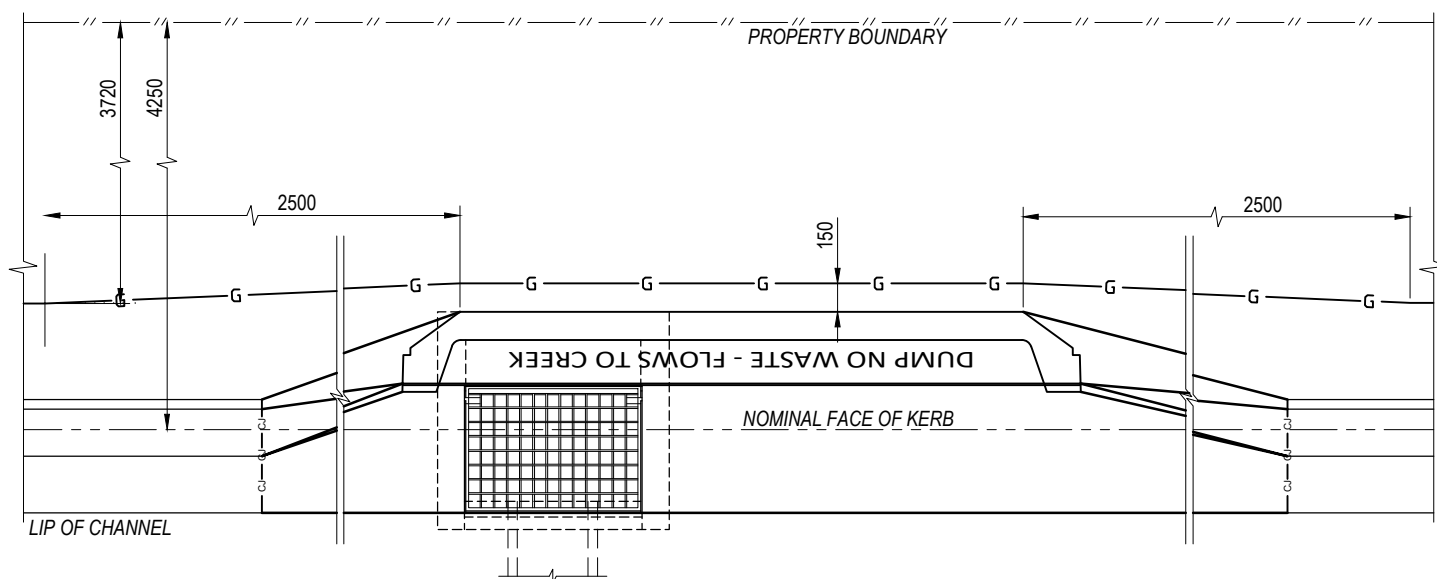

GAS RE-ALIGNMENT DETAILS

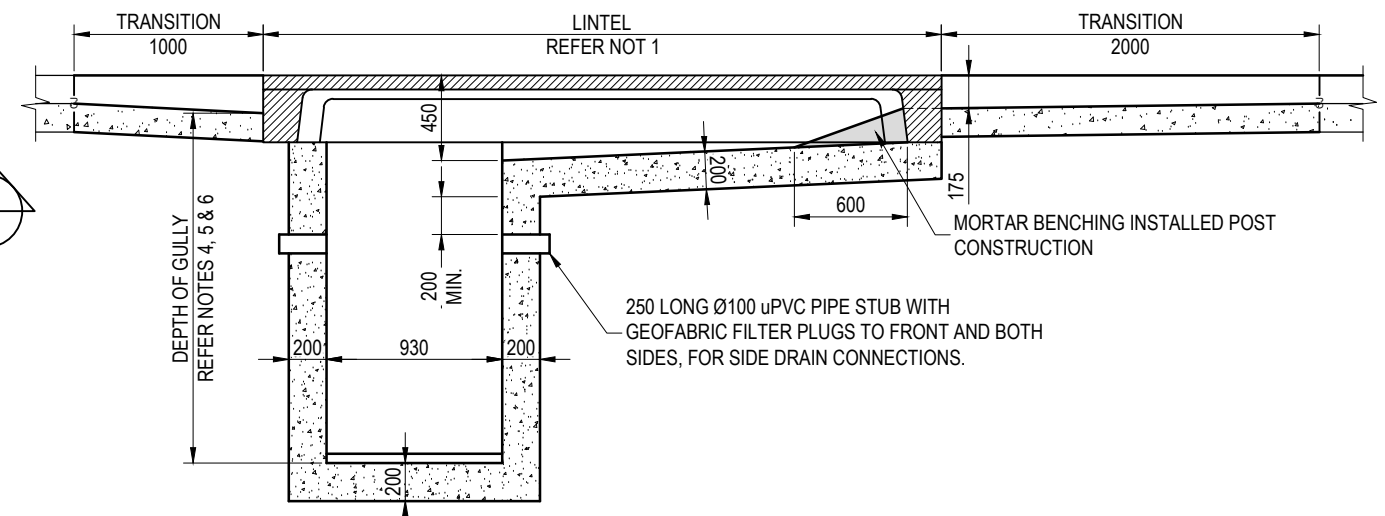

SECTION A - A

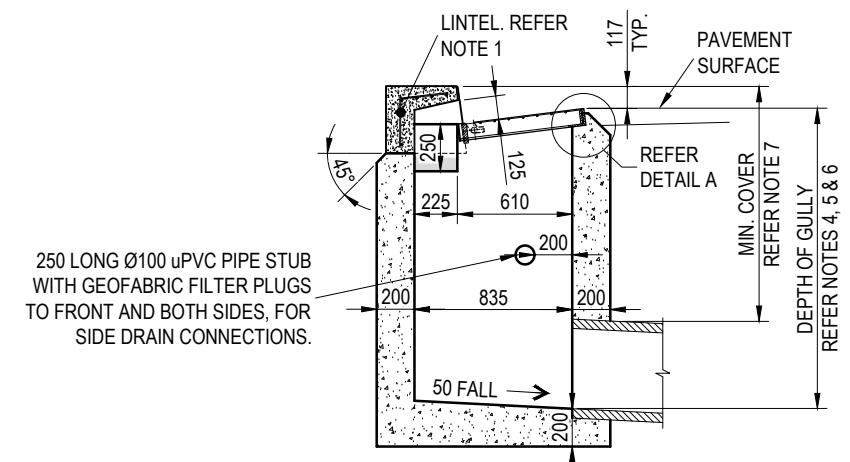

SECTION B - B

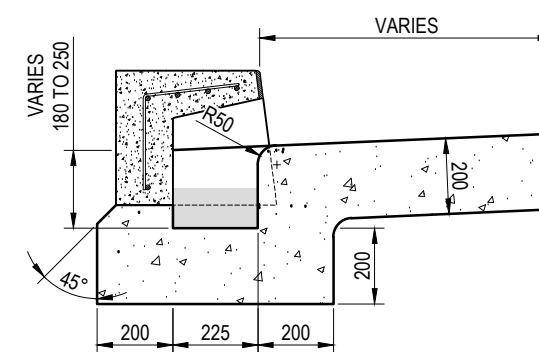

SECTION C - C

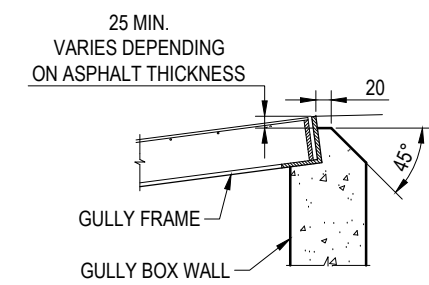

DETAIL A

NOTES:

1. REFER BSD-8055 FOR LINTEL DETAILS.
2. CAST INSITU CONCRETE N32 TO AS1379 AND AS3600.
3. REFER BSD-8053 & BSD-8054 FOR GULLY GRATE AND FRAME DETAILS.
4. LIMIT DEPTH OF STANDARD GULLY TO 1.80m.
5. STANDARD GULLIES BETWEEN 1.8 AND 3.0m ARE PERMITTED ONLY WITH THE PRIOR APPROVAL OF COUNCIL,
6. GULLIES DEEPER THAN 3.0m TO BE INDIVIDUALLY DESIGNED UNDER THE DIRECTION OF A SUITABLY QUALIFIED REGISTERED PROFESSIONAL ENGINEER OF QUEENSLAND (RPEQ).
7. INSTALL STEP IRONS TO GULLIES GREATER THAN 1.20m DEEP IN ACCORDANCE WITH AS1657.
8. REFER TO BSD-2042 (ROADWAYS) AND BSD-2043 (PATHS AND VERGES) FOR MINIMUM COVER REQUIREMENTS. MIN. 450mm IN OTHER AREAS.
9. DIMENSIONS IN MILLIMETRES (U.N.O.).

THE FITNESS FOR PURPOSE OF THIS STANDARD DRAWING FOR A SPECIFIC PROJECT SHALL BE ASSESSED AND ACCEPTED BY A SUITABLY QUALIFIED REGISTERED PROFESSIONAL ENGINEER OF QUEENSLAND (RPEQ).

	BRISBANE CITY COUNCIL STANDARD DRAWING		PUBLISH DATE
	<p>TYPE 'A' GULLY LIP IN LINE</p>		March 2021
			SCALE
	DRAWING NUMBER		NOT TO SCALE
ORIGINAL SIZE		REVISION	
A3		D	